

Installation Note

Add 4-Port Capability Upgrade Kit

To Upgrade PNA N5227A Option 219 to Option 419

Upgrade Kit Order Number: N5227AU- 619



Agilent Kit Number: N5227-60110
Agilent Document Number: N5227-90110
Printed in USA December 9, 2011
Supersedes: August 2011
© Agilent Technologies, Inc. 2011



N5227-90110

WARRANTY STATEMENT

THE MATERIAL CONTAINED IN THIS DOCUMENT IS PROVIDED "AS IS," AND IS SUBJECT TO BEING CHANGED, WITHOUT NOTICE, IN FUTURE EDITIONS. FURTHER, TO THE MAXIMUM EXTENT PERMITTED BY APPLICABLE LAW, AGILENT DISCLAIMS ALL WARRANTIES, EITHER EXPRESS OR IMPLIED WITH REGARD TO THIS MANUAL AND ANY INFORMATION CONTAINED HEREIN, INCLUDING BUT NOT LIMITED TO THE IMPLIED WARRANTIES OF MERCHANTABILITY AND FITNESS FOR A PARTICULAR PURPOSE. AGILENT SHALL NOT BE LIABLE FOR ERRORS OR FOR INCIDENTAL OR CONSEQUENTIAL DAMAGES IN CONNECTION WITH THE FURNISHING, USE, OR PERFORMANCE OF THIS DOCUMENT OR ANY INFORMATION CONTAINED HEREIN. SHOULD AGILENT AND THE USER HAVE A SEPARATE WRITTEN AGREEMENT WITH WARRANTY TERMS COVERING THE MATERIAL IN THIS DOCUMENT THAT CONFLICT WITH THESE TERMS, THE WARRANTY TERMS IN THE SEPARATE AGREEMENT WILL CONTROL.

DFARS/Restricted Rights Notice

If software is for use in the performance of a U.S. Government prime contract or subcontract, Software is delivered and licensed as "Commercial computer software" as defined in DFAR 252.227-7014 (June 1995), or as a "commercial item" as defined in FAR 2.101(a) or as "Restricted computer software" as defined in FAR 52.227-19 (June 1987) or any equivalent agency regulation or contract clause. Use, duplication or disclosure of Software is subject to Agilent Technologies' standard commercial license terms, and non-DOD Departments and Agencies of the U.S. Government will receive no greater than Restricted Rights as defined in FAR 52.227-19(c)(1-2) (June 1987). U.S. Government users will receive no greater than Limited Rights as defined in FAR 52.227-14 (June 1987) or DFAR 252.227-7015 (b)(2) (November 1995), as applicable in any technical data.

Safety Notes

The following safety notes are used throughout this document. Familiarize yourself with each of these notes and its meaning before performing any of the procedures in this document.

WARNING **Warning denotes a hazard. It calls attention to a procedure which, if not correctly performed or adhered to, could result in injury or loss of life. Do not proceed beyond a warning note until the indicated conditions are fully understood and met.**

CAUTION Caution denotes a hazard. It calls attention to a procedure that, if not correctly performed or adhered to, could result in damage to or destruction of the instrument. Do not proceed beyond a caution sign until the indicated conditions are fully understood and met.

Description of the Upgrade

This upgrade converts your N5227A Option 219 2-port analyzer to an N5227A Option 419 4-port analyzer by adding:

- an additional 26.5 GHz source board
- an additional 13.5 GHz source synthesizer board
- two additional 40 GHz doublers
- two additional 70 GHz doublers
- an additional mixer brick
- two additional receiver couplers and brackets
- two additional test port couplers
- two additional bias tees
- two additional source attenuators and brackets
- two additional receiver attenuators and brackets
- an additional cable guard for front panel jumpers
- a splitter
- a 3 dB pad
- a modified front panel
- many additional new cables

Getting Assistance from Agilent

Installing this upgrade kit requires special skills and experience. If you think you may not be qualified to do the work, or need advice, contact Agilent.

Contacting Agilent

Assistance with test and measurements needs and information on finding a local Agilent office are available on the Web at:

<http://www.agilent.com/find/assist>

If you do not have access to the Internet, please contact your Agilent field engineer.

NOTE In any correspondence or telephone conversation, refer to the Agilent product by its model number and full serial number. With this information, the Agilent representative can determine whether your product is still within its warranty period.

Getting Prepared

CAUTION The PNA contains extremely sensitive components that can be ruined if mishandled. Follow instructions carefully when making cable connections, especially wire harness connections.

The person performing the work accepts responsibility for the full cost of the repair or replacement of damaged components.

To successfully install this upgrade kit, you will need the following:

- A license key - refer to “[License Key Redemption](#)” below.
- A PDF copy or a paper copy of the PNA Service Guide - refer to “[Downloading the Online PNA Service Guide](#)” below.
- An ESD-safe work area - refer to “[Protecting Your Workspace from Electrostatic Discharge](#)” below.
- Correct tools - refer to “[Tools Required for the Installation](#)” on page 6.
- Enough time - refer to “[About Installing the Upgrade](#)” on page 6.
- Test equipment for the post-upgrade adjustments and full instrument calibration. To view the equipment list, click the Chapter 3 bookmark “[Tests and Adjustments](#)” in the PDF Service Guide¹.

License Key Redemption

NOTE The enclosed Option Entitlement Certificate is a receipt, verifying that you have purchased a licensed option for the PNA of your choice. You must now use an Agilent Web page to request a license key for the instrument that will receive the option.

To enable the option product, you must request a license key from: <http://www.agilent.com/find/softwarelicense>. To complete the request, you will need to gather the following information:

- From the certificate
 - Order number
 - Certificate number
- From your instrument
 - Model number
 - Serial number
 - Host ID

The instrument information is available on the network analyzer – on the analyzer’s **Help** menu, click **About Network Analyzer**.

If you provide an email address, Agilent will promptly email your license key. Otherwise, you will receive your license key via postal mail.

1. See “[Downloading the Online PNA Service Guide](#)” on page 5.

Downloading the Online PNA Service Guide

To view the online Service Guide for your PNA model number, use the following steps:

1. Go to www.agilent.com.
2. In the Search box, enter the model number of the analyzer (Ex: N5227A) and click **Search**.
3. Click [Technical Support > Manuals](#).
4. Click [Service Manual](#).
5. Click the service guide title to download the PDF file.
6. When the PDF of the Service Guide is displayed, scroll through the Contents section bookmarks to locate the information needed.

Protecting Your Workspace from Electrostatic Discharge

For information, click on the Chapter 1 bookmark, “Electrostatic Discharge Protection” in the PDF Service Guide¹.

ESD Equipment Required for the Installation

Description	Agilent Part Number
ESD grounding wrist strap	9300-1367
5-ft grounding cord for wrist strap	9300-0980
2 x 4 ft conductive table mat and 15-ft grounding wire	9300-0797
ESD heel strap (for use with conductive floors)	9300-1308

1. See “[Downloading the Online PNA Service Guide](#)” on page 5.

Tools Required for the Installation

Description	Qty	Part Number
T-6 TORX driver - set to 4 in-lbs (0.45 N.m)	1	N/A
T-8 TORX driver - set to 6 in-lbs (0.68 N.m)	1	N/A
T-10 TORX driver - set to 9 in-lbs (1.02 N.m)	1	N/A
T-20 TORX driver - set to 21 in-lbs (2.38 N.m)	1	N/A
5/16-in (8 mm) nutsetter or open end torque wrench- set to 10 in-lbs (1.13 N.m)	1	N/A
3/16-in (5 mm) nutsetter or open end torque wrench - set to 6 in-lbs (0.68 N.m)	1	N/A
5/8-in (16 mm) nutsetter or open end torque wrench - set to 21 in-lbs (2.38 N.m)	1	N/A
9 mm nutsetter or open end torque wrench - set to 21 in-lbs (2.38 N.m)	1	N/A
1-in (25.4 mm) torque wrench - set to 72 in-lbs (8.15 N.m)	1	N/A

CAUTION Use a 5/16-in torque wrench set to 10 in-lbs on all cable connections except the front and rear panel bulkhead connectors. On these, use a 9 mm nutsetter or open end torque wrench set to 21 in-lb.

About Installing the Upgrade

Products affected	N5227A Option 219
Installation to be performed by	Agilent service center or personnel qualified by Agilent
Estimated installation time	5 hours
Estimated adjustment time	0.5 hours
Estimated full instrument calibration time	4.5 hours

Items Included in the Upgrade Kit¹

Check the contents of your kit against the following list. If any part is missing or damaged, contact Agilent Technologies. Refer to [“Contacting Agilent”](#) on page 3.

Table 1 Contents of Upgrade Kit N5227-60110

Ref Desig.	Description	Qty	Part Number
-	Installation note (this document)	1	N5227-90110
A10	26.5 GHz source (2) board	1	5087-7780
A12	40 GHz doubler assembly port 3	2	5087-7346
A13	40 GHz doubler assembly port 4		
A17	13.5 GHz (source 2) synthesizer board	1	N5242-60150
A26	Splitter	1	5067-4086
A28	Mixer brick (2)	1	5087-7337
A30	Test port 3 receiver coupler	2	5087-7744
A31	Test port 4 receiver coupler		
A34	Test port 3 coupler	2	5087-7778
A35	Test port 4 coupler		
A39	Test port 3 source attenuator	2	84905-60002
A40	Test port 4 source attenuator		
A43	Test port 3 bias tee	2	5087-7732
A44	Test port 4 bias tee		
A47	Test port 3 receiver attenuator	2	84905-60002
A48	Test port 4 receiver attenuator		
A61	Test port 3 70 GHz doubler assembly	2	5087-7336
A62	Test port 4 70 GHz doubler assembly		
A69	3-dB attenuator	1	08490-60037
-	Front frame, 4-port	1	N5247-20141
-	Bulkhead connector, front panel	12	5065-4673
-	Washer for bulkhead connectors, front panel	12	1250-3310
-	Nut for bulkhead connectors, front panel	12	1250-3516
-	Machine screw, M2.0 x 6, pan head (8 to attach 2 receiver couplers to brackets)	10	0515-0658
-	Machine screw, M3 x 10, pan head (2 to attach cable bracket mount to test set deck)	3	0515-0374
-	Machine screw, M3 x 16, pan head (6 to attach 2 70 GHz doublers to mounts)	8	0515-0375

1. In addition to the upgrade kit, the shipment includes an Option Entitlement Certificate. Refer to [“License Key Redemption”](#) on page 4 for important information about this certificate.

Table 1 Contents of Upgrade Kit N5227-60110

Ref Desig.	Description	Qty	Part Number
-	Machine screw, M4.0 x 10, pan head (2 to attach brace N5247-20134 to 70 GHz doubler mounts; 2 each to attach the following boards to the analyzer chassis: A17 13.5 GHz synthesizer board, A10 26.5 GHz source board, A12 40 GHz doubler assembly port 3, and A13 40 GHz doubler assembly port 4.)	13	0515-0380
-	Machine screw, M3.0 x 8, pan head (8 to attach port 3 and port 4 attenuator assemblies to deck; 8 to attach 2 src attn and 2 rcvr attn to brackets; 6 to attach receiver coupler assemblies to attenuator assembly brackets; 4 to attach brace N5247-20134 to attenuator pair brackets; 4 to attach brace N5247-20133 to attenuator pair brackets)	35	0515-0372
-	Machine screw, M2.5 x 16, pan head (2 to attach splitter to mixer brick)	3	0515-2007
-	Machine screw, M3.0 x 6, flat head (4 to attach 2 bias tees to blocks)	5	0515-1227
-	Machine screw, M3.0 x 35, pan head (3 to attach A28 mixer brick to block)	4	0515-1038
-	Machine screw, M3.0 x 20, flat head (2 to attach bracket to A10 26.5 GHz source)	3	0515-2078
-	Machine screw, M3.0 x 18, pan head (1 to attach bracket to A10 26.5 GHz source)	2	0515-0666
-	Front panel overlay (label), 4-port	1	N5227-80005
-	Keypad overlay (label)	1	N5242-80005
-	Power button overlay (label)	1	N5242-80007
-	Nameplate, N5227A	1	N5227-80001
-	Test set front plate, 4-port	1	N5247-00009
-	Protective cap, black plastic	2	1401-0214
-	Pad (between each receiver coupler and the bracket for the attenuator pairs)	2	0403-0179
-	Gap pad (between each test coupler and the test set front plate)	4	E4403-20033
-	3 dB pad, attached to R4 connector on A28 mixer brick	1	08490-60037
-	Vibration mount (between couplers 1 & 3, and 2 & 4)	2	0460-2725
-	Mounting nuts (for port 3 & 4 test port couplers)	2	5022-1087
-	Cable guard, center jumper cables	1	N5242-00030
-	Cable clamp, 1 to secure W145 (N5247-20066); 1 to secure W41 (N5247-20069); 1 to secure W37 (N5247-20070); 3 to secure W45 (N5247-20058); 1 to secure W52 (N5247-20012).	12	1400-1334
-	Cable tie wrap, 1 to secure W93 and W94 cable ends together; 1 to secure W95 and W96 cable ends together; 1 to secure W55 (N5247-20067); 1 to secure W37 (N5247-20070); 1 to secure W54 (N5247-20062); 2 to secure W144 (N5247-20071).	12	1400-0249
-	Bracket, rear, bottom side - for semi rigid cables	1	N5247-00006
-	Bracket for receiver coupler, port 3	1	N5247-00012
-	Bracket for receiver coupler, port 4	1	N5247-00011
-	Bracket for receiver attenuator and source attenuator pairs	2	N5247-00005
-	Bracket for A10 26.5 GHz source (2) board	1	N5247-20136
-	Brace, bottom side of PNA	1	N5247-20133
-	Brace, bottom side of PNA	2	N5247-20134

Table 1 Contents of Upgrade Kit N5227-60110

Ref Desig.	Description	Qty	Part Number
W2	RF cable, A10 source (2) P1 to A17 13.5 GHz source (2) synthesizer J1207	1	N5245-20100
W7	RF cable, A10 source (2) P5 to A12 port 3 40 GHz doubler P1	1	N5245-20034
W8	RF cable, A10 source (2) P3 to A13 port 4 40 GHz doubler P1	1	N5247-20125
W9	RF cable, A10 source (2) P4 to A12 port 3 40 GHz doubler P4	1	N5245-20032
W10	RF cable, A12 port 3 40 GHz doubler P3 to A13 port 4 40 GHz doubler P4	1	N5245-20033
W15	RF cable, A12 port 3 40 GHz doubler P6 to W16	1	N5247-20114
W16	RF cable, A61 port 3 70 GHz doubler to W15	1	N5247-20060
W17	RF cable, A12 port 3 40 GHz doubler P2 to W18	1	N5247-20086
W18	RF cable, A61 port 3 70 GHz doubler to W17	1	N5247-20084
W19	RF cable, A13 port 4 40 GHz doubler P6 to W20	1	N5247-20114
W20	RF cable, A62 port 4 70 GHz doubler to W19	1	N5247-20015
W21	RF cable, A13 port 4 40 GHz doubler P2 to W22	1	N5247-20086
W22	RF cable, A62 port 4 70 GHz doubler to W21	1	N5247-20068
W28	RF cable, A61 port 3 70 GHz doubler to A30 port 3 receiver coupler	1	N5247-20043
W29	RF cable, A62 port 4 70 GHz doubler to A31 port 4 receiver coupler	1	N5247-20044
W34	RF cable, A33 port 1 coupler to front-panel Port 1 CPLR ARM	1	N5247-20082
W37	RF cable, A30 port 3 ref coupler to front-panel REF 3 SOURCE OUT	1	N5247-20070
W38	RF cable, A34 port 3 coupler to front-panel Port 3 CPLR ARM	1	N5247-20007
W41	RF cable, A31 port 4 ref coupler to front-panel REF 4 SOURCE OUT	1	N5247-20069
W42	RF cable, A35 port 4 coupler to front-panel Port 4 CPLR ARM	1	N5247-20026
W46	RF cable, A36 port 2 coupler to front-panel port 2 CPLR ARM	1	N5247-20019
W54	RF cable, REF 3 RCVR R3 IN to A28 mixer brick (R3)	1	N5247-20062
W55	RF cable, REF 4 RCVR R4 IN to A28 mixer brick (R4)	1	N5247-20067
W58	RF cable, 2.4 mm cap for A28 mixer brick	1	N5247-20138
W60	RF cable, front panel jumper	6	N5247-20107
W62	RF cable, A25 HMA26.5 to A26 splitter	1	N5247-20111
W63	RF cable, A26 splitter to A27 mixer brick	1	N5245-20023
W64	RF cable, A26 splitter to A28 mixer brick	1	N5245-20022
W67	RF cable, A12 port 3 40 GHz doubler P5 to W68	1	N5247-20096
W68	RF cable, rear-panel port RF2 OUT (J12) to W67	1	N5247-20088
W72	RF cable, A27 mixer brick (R1) to A24 IF multiplexer (P411)	1	N5242-60021
W73	RF cable, A27 mixer brick (R2) to A24 IF multiplexer (P412)	1	N5242-60022
W75	RF cable, A28 mixer brick (D) to A24 IF multiplexer (P801)	1	N5242-60024
W76	RF cable, A28 mixer brick (R4) to A24 IF multiplexer (P414)	1	N5242-60019
W77	RF cable, A28 mixer brick (R3) to A24 IF multiplexer (P413)	1	N5242-60020
W78	RF cable, A28 mixer brick (C) to A24 IF multiplexer (P601)	1	N5242-60023
W80	RF cable, A24 IF multiplexer board P203 to A16 SPAM board J2	1	N5242-60013

Table 1 Contents of Upgrade Kit N5227-60110

Ref Desig.	Description	Qty	Part Number
W82	RF cable, A24 IF multiplexer board P603 to A16 SPAM board J5	1	N5242-60015
W87	RF cable, A14 frequency ref (J7) to A17 13.5 GHz (source 2) synth (J5)	1	N5242-60030
W93	RF cable, A61 port 3 70 GHz dblr J2 to A12 40 GHz dblr J401	1	N5247-60010
W94	RF cable, A61 port 3 70 GHz dblr J4 to A12 40 GHz dblr J500	1	N5247-60011
W95	RF cable, A62 port 4 70 GHz doubler (J2) to A13 40 GHz doubler (J401)	1	N5247-60012
W96	RF cable, A62 port 4 70 GHz dblr J4 to A13 40 GHz dblr J500	1	N5247-60013
W103	RF cable, front-panel Port 1 CPLR THRU to A42 port 1 bias tee	1	N5247-20010
W104	RF cable, A33 port 1 coupler to A42 port 1 bias tee	1	N5247-20022
W105	RF cable, A30 port 3 receiver coupler to A39 port 3 source attenuator	1	N5247-20083
W106	RF cable, A39 port 3 source attenuator to front-panel Port 3 SOURCE OUT	1	N5247-20009
W107	RF cable, A43 port 3 bias tee to port 3 CPLR THRU	1	N5247-20081
W108	RF cable, A43 port 3 bias tee to A34 port 3 coupler	1	N5247-20028
W109	RF cable, A31 port 4 receiver coupler to A40 port 4 source attenuator	1	N5247-20083
W110	RF cable, A40 port 4 source attenuator to front-panel Port 4 SOURCE OUT	1	N5247-20025
W111	RF cable, port 4 CPLR THRU to A44 port 4 bias tee	1	N5247-20021
W112	RF cable, A44 port 4 bias tee to A35 port 4 coupler	1	N5247-20029
W116	RF cable, A45 port 2 bias tee to A36 port 2 coupler	1	N5247-20080
W119	RF cable, port 3 RCVR C IN to A47 port 3 receiver attenuator	1	N5247-20008
W120	RF cable, A47 port 3 receiver attenuator to A28 mixer brick (C)	1	N5247-20064
W121	RF cable, Port 4 RCVR D IN to A48 port 4 receiver attenuator	1	N5247-20024
W122	RF cable, A48 port 4 receiver attenuator to A28 mixer brick (D)	1	N5247-20065
W144	RF cable, A29 port 1 receiver coupler to A37 reference mixer switch	1	N5247-20071
W145	RF cable, REF 2 RCVR R2 IN to A27 mixer brick (R2)	1	N5247-20066
-	Ribbon cable, A23 test set motherboard J547 to A39 port 3 source attenuator	2	N5245-60006
-	Ribbon cable, A23 test set motherboard J548 to A40 port 4 source attenuator		
-	Ribbon cable, A23 test set motherboard J5 to A61 port 3 70 GHz doubler J1	2	N5247-60018
-	Ribbon cable, A23 test set motherboard J3 to A62 port 4 70 GHz doubler J1		
-	Ribbon cable, A23 test set motherboard J206 to A47 port 3 receiver attenuator	2	N5247-60020
-	Ribbon cable, A23 test set motherboard J207 to A48 port 4 receiver attenuator		
-	Ribbon cable, A23 test set motherboard J552 to A28 mixer brick (2) J52	1	N5247-60015
-	Wire harness, A43 port 3 bias tee to A23 test set motherboard J543	2	N5247-60021
-	Wire harness, A44 port 4 bias tee to A23 test set motherboard J544		

NOTE Extra quantities of items such as protective plastic caps, screws, cable ties, and cable clamps may be included in this upgrade kit. It is normal for some of these items to remain unused after the upgrade is completed.

Installation Procedure for the Upgrade

The network analyzer must be in proper working condition prior to installing this option. Any necessary repairs must be made before proceeding with this installation.

WARNING This installation requires the removal of the analyzer's protective outer covers. The analyzer must be powered down and disconnected from the mains supply before performing this procedure.

Overview of the Installation Procedure

- Step 1. Obtain a Keyword and Verify the Information.
- Step 2. Remove the Outer Cover.
- Step 3. Remove the Inner Cover.
- Step 4. Remove the Front Panel Jumper Cables and Cable Guards.
- Step 5. Remove the Front Panel Assembly.
- Step 6. Remove the Braces on the Bottom Side of the PNA.
- Step 7. Remove the A23 Test Set Motherboard.
- Step 8. Remove the Testset Stabilizer Bracket from the A24 IF Multiplexer Board.
- Step 9. Remove Some Bottom-Side (Test Set) Cables.
- Step 10. Remove the A60 70 GHz Doubler Assembly From the Test Set Deck.
- Step 11. Assemble the A61 70 GHz Doubler on the Doubler Mount.
- Step 12. Reinstall the A60/A61 70 GHz Doubler Assembly.
- Step 13. Remove the A63 70 GHz Doubler Assembly From the Test Set Deck.
- Step 14. Assemble the A62 70 GHz Doubler on the Doubler Mount.
- Step 15. Reinstall the A62/A63 70 GHz Doubler Assembly.
- Step 16. Install Bracket to A10 Source Assembly.
- Step 17. Assemble the A10 26.5 GHz Source 2 Assembly.
- Step 18. Assemble and Install the A13 40 GHz Doubler Assembly.
- Step 19. Install the A13 40 GHz Doubler Cables.
- Step 20. Assemble and Install the A12 40 GHz Doubler Assembly.
- Step 21. Install the A12 40 GHz Doubler Cables.
- Step 22. Install the A10 26.5 GHz Source 2 Assembly and Cables.
- Step 23. Install the A17 13.5 GHz (Source 2) Synthesizer Board and Cables.
- Step 24. Install the Cable Bracket Mount.
- Step 25. Remove the A27 Mixer Brick Assembly.

- Step 26. Assemble the A28 Mixer Brick Assembly.
- Step 27. Install the A27/A28 Mixer Brick Assemblies.
- Step 28. Assemble the Port 3 and Port 4 Attenuator Assemblies.
- Step 29. Install the Port 3 and Port 4 Attenuator Assemblies on the Test Set Deck.
- Step 30. Assemble the A30 and A31 receiver coupler Assemblies.
- Step 31. Install the A30 and A31 receiver coupler Assemblies.
- Step 32. Remove the Bias Tee Blocks From the Test Set Deck.
- Step 33. Install the A43 and A44 Bias Tees on the Bias Tee Blocks.
- Step 34. Reinstall the Bias Tee Blocks.
- Step 35. Assemble the A33 - A36 Test Port Coupler Assemblies.
- Step 36. Remove and Disassemble the 2-Port Test Set Front Plate.
- Step 37. Install the LED Boards, Bulkhead Connectors, and Test Port Coupler Assemblies to the 4-Port Test Set Front Plate.
- Step 38. Install the 4-Port Coupler Plate Assembly to the Deck.
- Step 39. Install Some Bottom-Side (Test Set) Cables.
- Step 40. Install Cables on IF Multiplexer Board.
- Step 41. Reinstall the Testset Stabilizer Bracket on the A24 IF Multiplexer Board.
- Step 42. Reinstall the A23 Test Set Motherboard.
- Step 43. Install Cables on the A23 Test Set Motherboard.
- Step 44. Install the Braces on the Bottom Side of the PNA.
- Step 45. Replace the Front Frame in the Front Panel Assembly.
- Step 46. Reinstall Front Panel Assembly.
- Step 47. Install the Overlays and Nameplate.
- Step 48. Install the Jumper Cables.
- Step 49. Reinstall the Inner Cover.
- Step 50. Reinstall the Outer Cover.
- Step 51. Enable Options P04 (400) and 419.
- Step 52. Perform Post-Upgrade Adjustments and Calibration.
- Step 53. Prepare the PNA for the User.

Step 1. Obtain a Keyword and Verify the Information

Follow the instructions on the Option Entitlement Certificate supplied to obtain a license key for installation of this upgrade. Refer to [“License Key Redemption” on page 4](#).

Verify that the model number, serial number, and option number information on the license key match those of the instrument on which this upgrade will be installed.

If the model number, serial number, or option number do not match those on your license key, you will not be able to install the option. If this is the case, contact Agilent for assistance before beginning the installation of this upgrade. Refer to [“Contacting Agilent” on page 3](#).

Once the license key has been received and the information verified, you can proceed with the installation at step 2.

Step 2. Remove the Outer Cover

For instructions, click the Chapter 7 bookmark “Removing the Covers” in the PDF Service Guide¹.

Step 3. Remove the Inner Cover

For instructions, click the Chapter 7 bookmark “Removing the Covers” in the PDF Service Guide¹.

Step 4. Remove the Front Panel Jumper Cables and Cable Guards

1. Pull the two cable guards off of the front panel jumper cables. Save them for reinstallation later.
2. Remove all front panel jumper cables. Keep for reinstallation later.

Step 5. Remove the Front Panel Assembly

For instructions, click the Chapter 7 bookmark “Removing and Replacing the Front Panel Assembly” in the PDF Service Guide¹.

Step 6. Remove the Braces on the Bottom Side of the PNA

1. Remove the three braces shown in [Figure 1](#).
2. Discard brace N5247-20131 and the screws that secure it.
3. Keep both of the N5247-20132 braces and their screws for reinstallation later.

1. See [“Downloading the Online PNA Service Guide” on page 5](#).

Figure 1 Braces on Bottom Side of Option 219 PNA

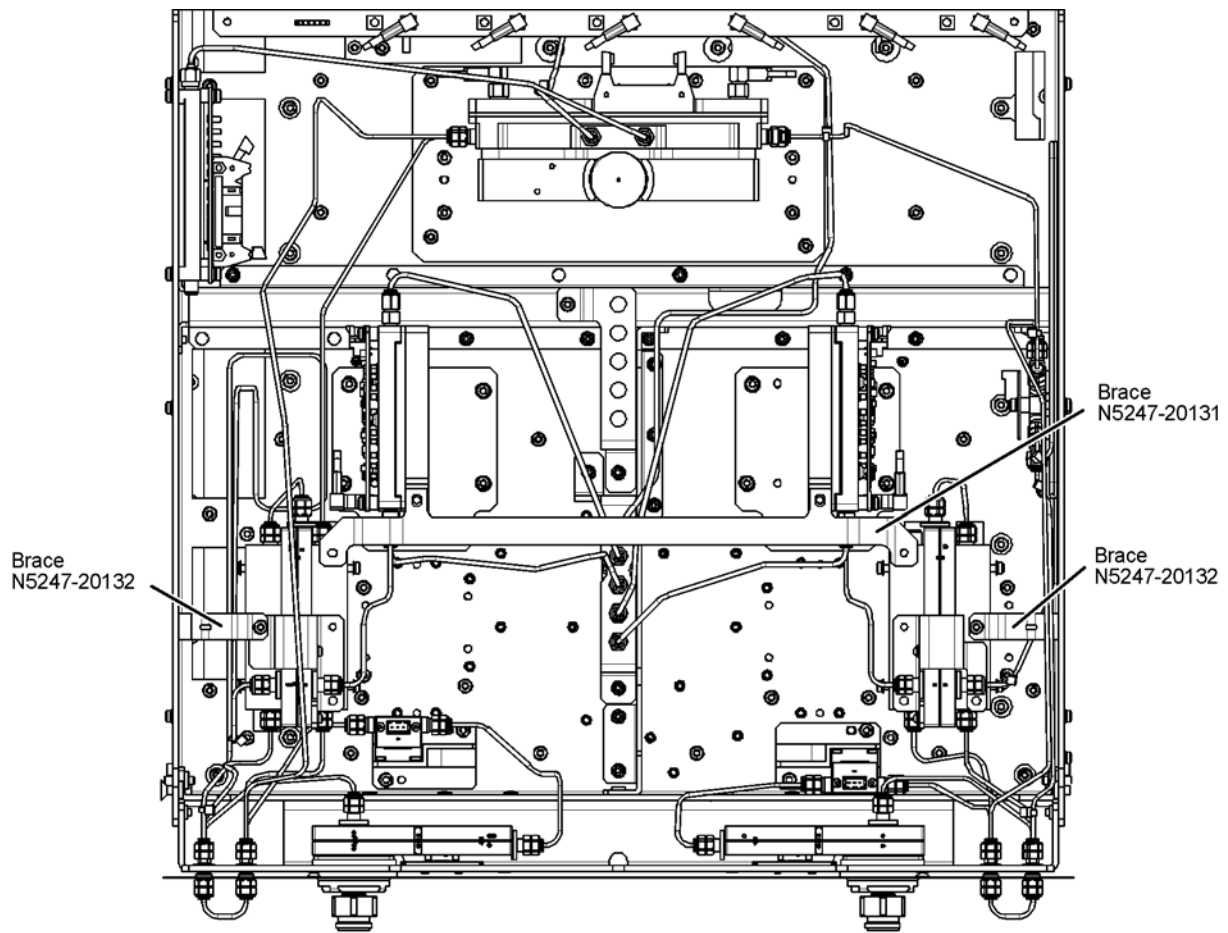

n5247_106_33

Step 7. Remove the A23 Test Set Motherboard

For instructions, click the Chapter 7 bookmark "Removing and Replacing the A23 Test Set Motherboard" in the PDF Service Guide¹.

Step 8. Remove the Testset Stabilizer Bracket from the A24 IF Multiplexer Board

Remove the stabilizer bracket as shown in [Figure 2](#).

Figure 2 Testset Stabilizer Bracket on A24 IF MUX Board

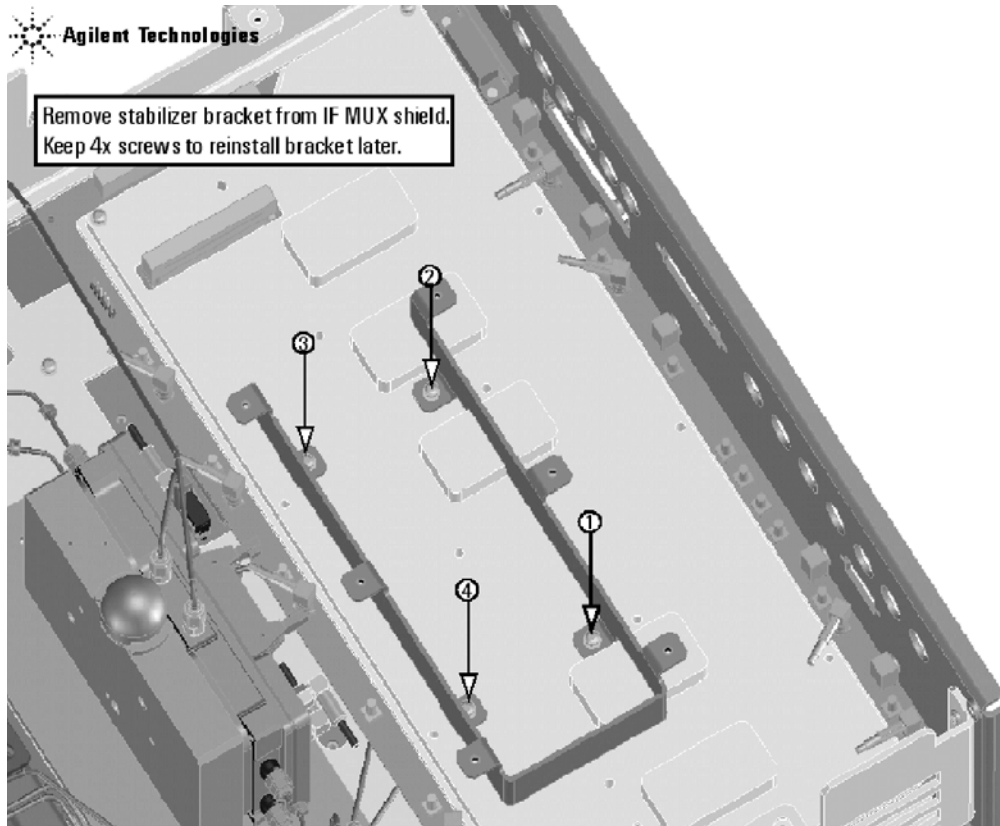

N5247_106_10

Step 9. Remove Some Bottom-Side (Test Set) Cables

CAUTION Be careful not to damage the center pins of the semirigid cables. Some flexing of the cables may be necessary but do not over-bend them.

NOTE When removing a cable, also remove the plastic cable clamp, if present. It is normal for some of the cable clamp's adhesive to remain.

1. Place the analyzer bottom-side up on a flat surface.
2. Remove all bottom-side cables (gray flexible and silver semi-rigid) except for those in the following table. Do not discard the cables that are removed because some will be reused later in the procedure. To see an image showing the location of cables W11, W13, W23, W25, W61, and W65, click the Chapter 6 bookmark "Top Cables, All Cables - All Options" in the PDF Service Guide¹. To see an image showing the location of cable W66, click the Chapter 6 bookmark "Bottom RF Cables, 2-Port, Option 219" in the PDF Service Guide¹.

Do Not Remove These Bottom-Side Cables				
Reference Designator	Type ^a	Part Number	Qty	Description
W11	SR	N5247-20114	1	A7 port 1 40 GHz doubler P6 to W12
W13	SR	N5247-20086	1	A7 port 1 40 GHz doubler P2 to W14
W23	SR	N5247-20114	1	A8 port 2 40 GHz doubler P6 to W24
W25	SR	N5247-20086	1	A8 port 2 40 GHz doubler P2 to W26
W61	SR	N5247-20110	1	A15 13.5 GHz (LO) synthesizer board J1207 to A25 HMA26.5
W65	SR	N5247-20113	1	A7 port 1 40 GHz doubler P5 to W66
W66	SR	N5247-20109	1	W65 to rear-panel EXT TSET DRIVE RF OUT (J6)

a. SR = semirigid coaxial cable.

3. Remove and discard the following gray flexible cables that have a top-side connection:
 - W82 (N5247-60023) A16 SPAM board (J2) to A24 IF multiplexer (P603)
 - W80 (N5247-60024) A16 SPAM board (J5) to A24 IF multiplexer (P203)
4. Leave the remaining gray flexible cables, the wire harnesses, and the ribbon cables connected where possible. Any that are removed should be labeled for reconnection later.

Step 10. Remove the A60 70 GHz Doubler Assembly From the Test Set Deck

Remove the 70 GHz doubler 1 assembly from the test set deck. For instructions, click the Chapter 7 bookmark, "Removing and Replacing the A60-A63 70 GHz Doublers" in the PDF Service Guide¹. Keep all parts for reinstallation later.

1. See "Downloading the Online PNA Service Guide" on page 5.

Step 11. Assemble the A61 70 GHz Doubler on the Doubler Mount

1. Follow the instruction in [Figure 3](#) to install the A61 70 GHz doubler 3 on the doubler mount. New parts are listed in [Table 1 on page 7](#) of this document.

Figure 3 **Installing A61 Doubler 3 on the Doubler Mount**

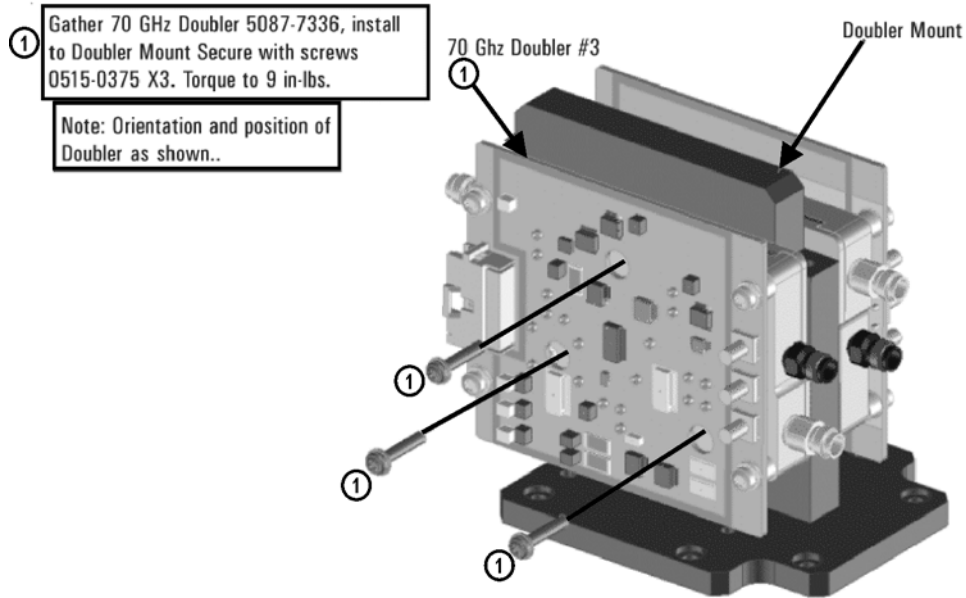

N5247_106_35

2. Connect the cables to the A61 70 GHz doubler 3 in the order shown in [Figure 4](#). The other ends of the cables will be connected later.

Figure 4 A61 70 GHz Doubler Assembly



Note: Orientation of the coax cables.

- ① Install Coax Cable N5247-60010 to J2 on doubler #3.
- ② Install Coax Cable N5247-60011 to J4 on doubler #3.
- ③ Install Ribbon Cable N5247-60018 to doubler #3 as shown.
- ④ Add tie wrap, 1400-0249 to keep cable ends together.

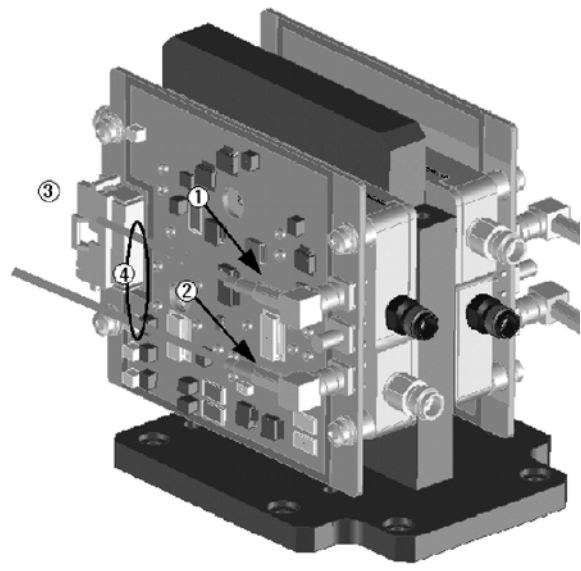

N5247_106_36

Step 12. Reinstall the A60/A61 70 GHz Doubler Assembly

Reinstall the A60 70 GHz doubler 1 cables, and then reinstall the A60/A61 70 GHz doubler assembly on the test set deck, reusing the existing screws. For instructions, click the Chapter 7 bookmark, "Removing and Replacing the A60-A63 70 GHz Doublers" in the PDF Service Guide¹.

Step 13. Remove the A63 70 GHz Doubler Assembly From the Test Set Deck

Remove the A63 70 GHz doubler 2 assembly from the test set deck. For instructions, click the Chapter 7 bookmark, "Removing and Replacing the A60-A63 70 GHz Doublers" in the PDF Service Guide¹. Keep all parts for reinstallation later.

1. See "Downloading the Online PNA Service Guide" on page 5.

Step 14. Assemble the A62 70 GHz Doubler on the Doubler Mount

1. Follow the instruction in [Figure 5](#) to install the A62 70 GHz doubler 4 on the doubler mount. New parts are listed in [Table 1 on page 7](#) of this document.

Figure 5 **Installing A62 Doubler 4 on the Doubler Mount**

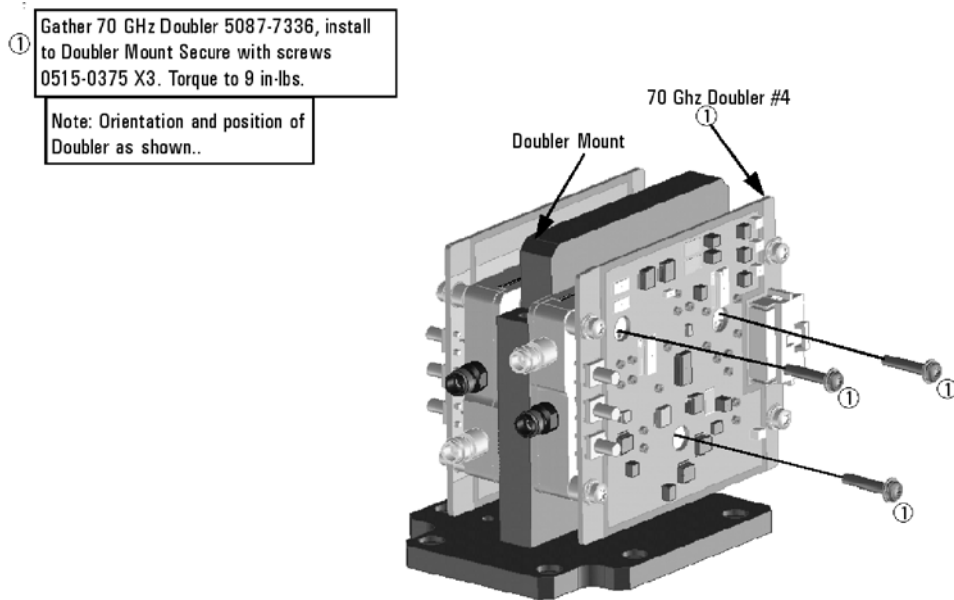

N5247_106_37

2. Connect the cables to the A62 70 GHz doubler in the order shown in [Figure 6](#). The other ends of the cables will be connected later.

Figure 6 A62 70 GHz Doubler Assembly



Note: Orientation of the coax cables.

- ① Install Coax Cable N5247-60012 to J2 on doubler #4.
- ② Install Coax Cable N5247-60013 to J4 on doubler #4.
- ③ Install Ribbon Cable N5247-60018 to doubler #4 as shown.
- ④ Add tie wrap, 1400-0249 to keep cable ends together.

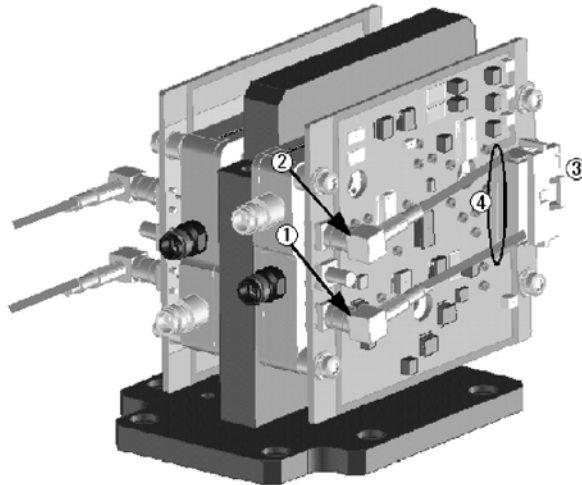

N5247_106_38

Step 15. Reinstall the A62/A63 70 GHz Doubler Assembly

Reinstall the A63 70 GHz doubler 2 cables, and then reinstall the A62/A63 70 GHz doubler assembly on the test set deck, reusing the existing screws. For instructions, click the Chapter 7 bookmark, "Removing and Replacing the A60-A63 70 GHz Doublers" in the PDF Service Guide¹.

1. See "Downloading the Online PNA Service Guide" on page 5.

Step 16. Install Bracket to A10 Source Assembly

Follow the two instructions shown in [Figure 7](#).

Figure 7 A10 Source 2 Assembly Bracket Installation

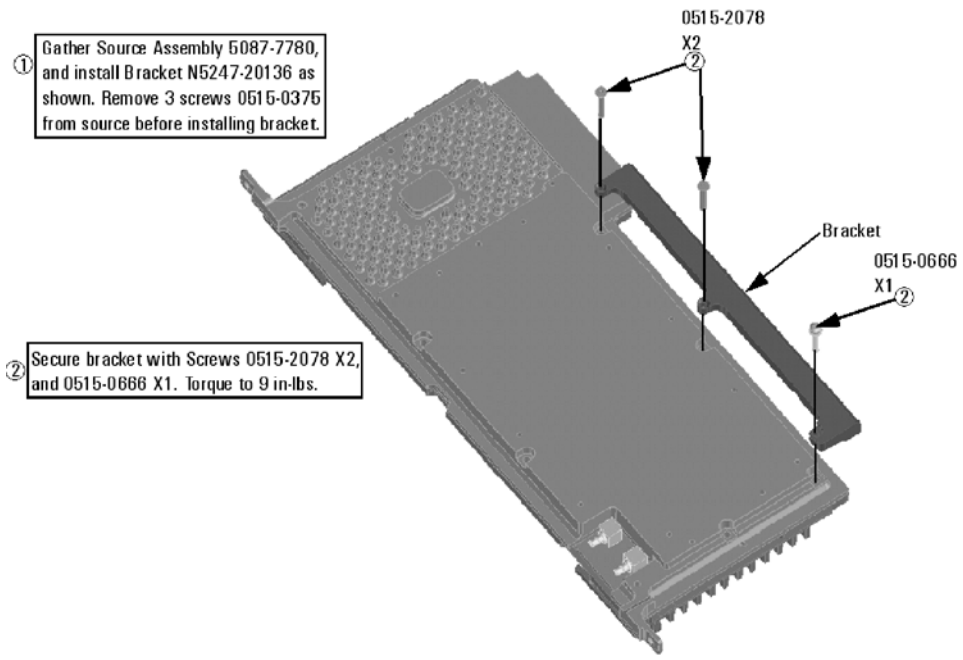

N5247_106_39

Step 17. Assemble the A10 26.5 GHz Source 2 Assembly

Follow the four instructions shown in [Figure 8](#).

Figure 8 A10 Source 2 Assembly

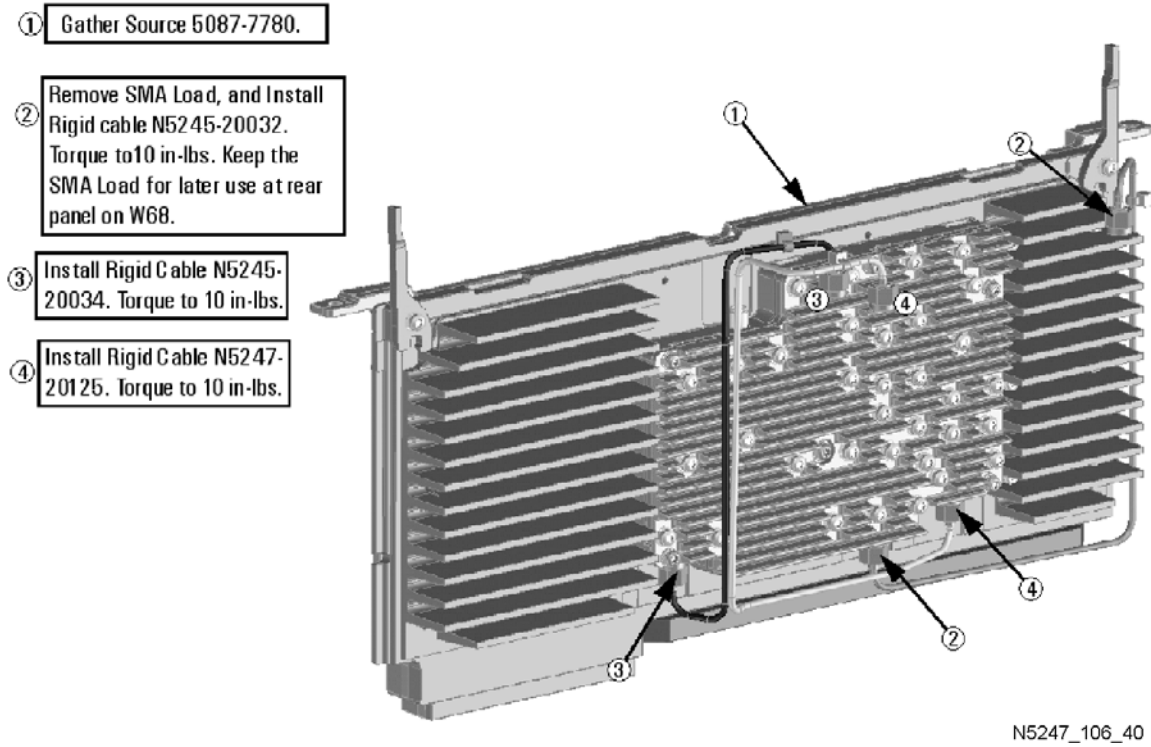

Step 18. Assemble and Install the A13 40 GHz Doubler Assembly

Follow the five instructions shown in [Figure 9](#).

Figure 9 A13 40 GHz Doubler 4 Installation

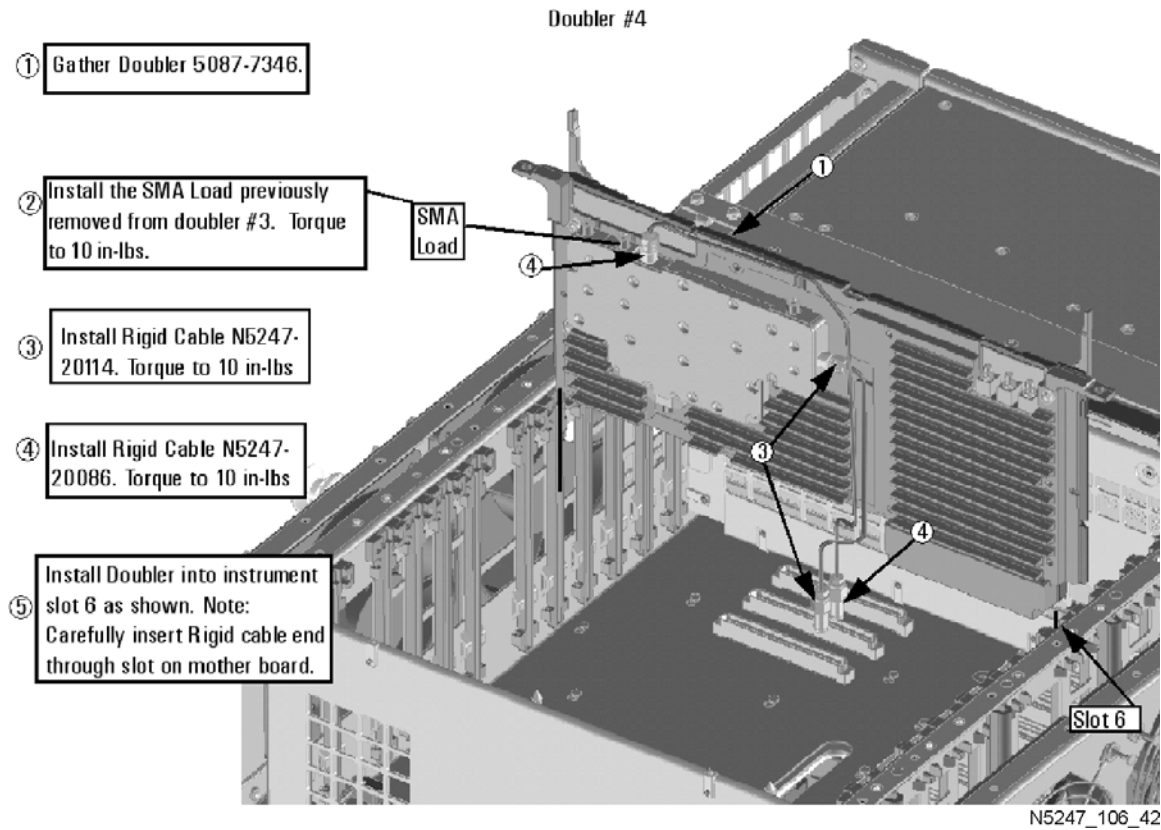

Step 19. Install the A13 40 GHz Doubler Cables

Follow the three instructions shown in [Figure 10](#).

Figure 10 A13 40 GHz Doubler 4 Cable Installation

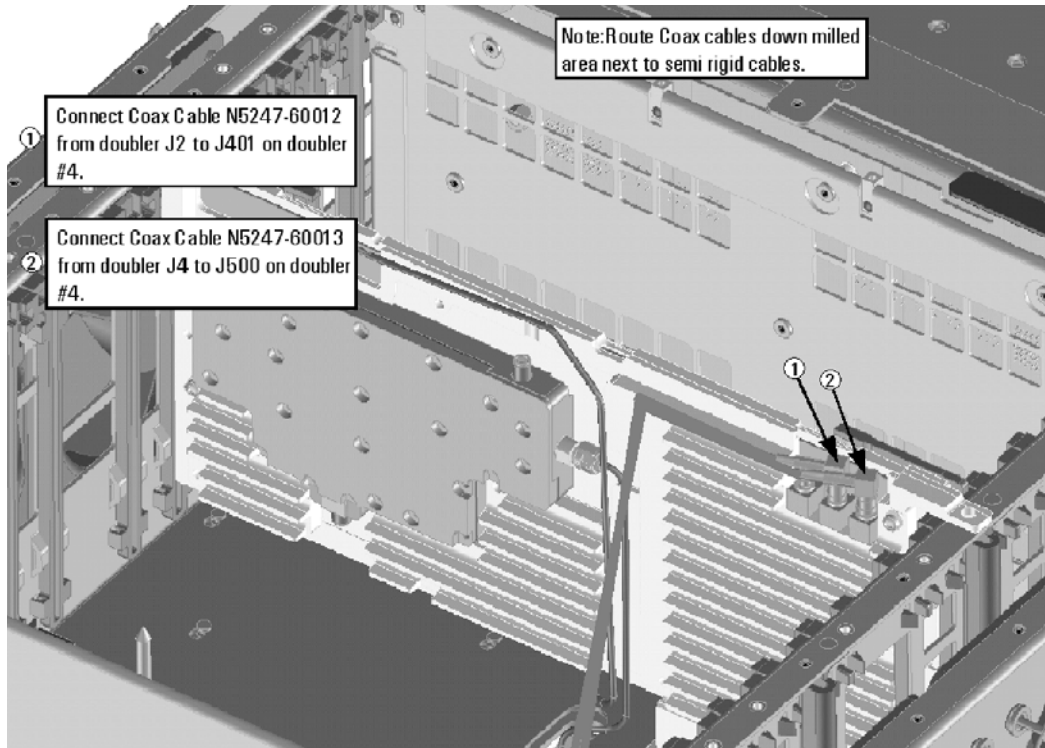

N5247_106_43

Step 20. Assemble and Install the A12 40 GHz Doubler Assembly

Follow the five instructions shown in [Figure 11](#).

Figure 11 A12 40 GHz Doubler 3 Assembly Installation

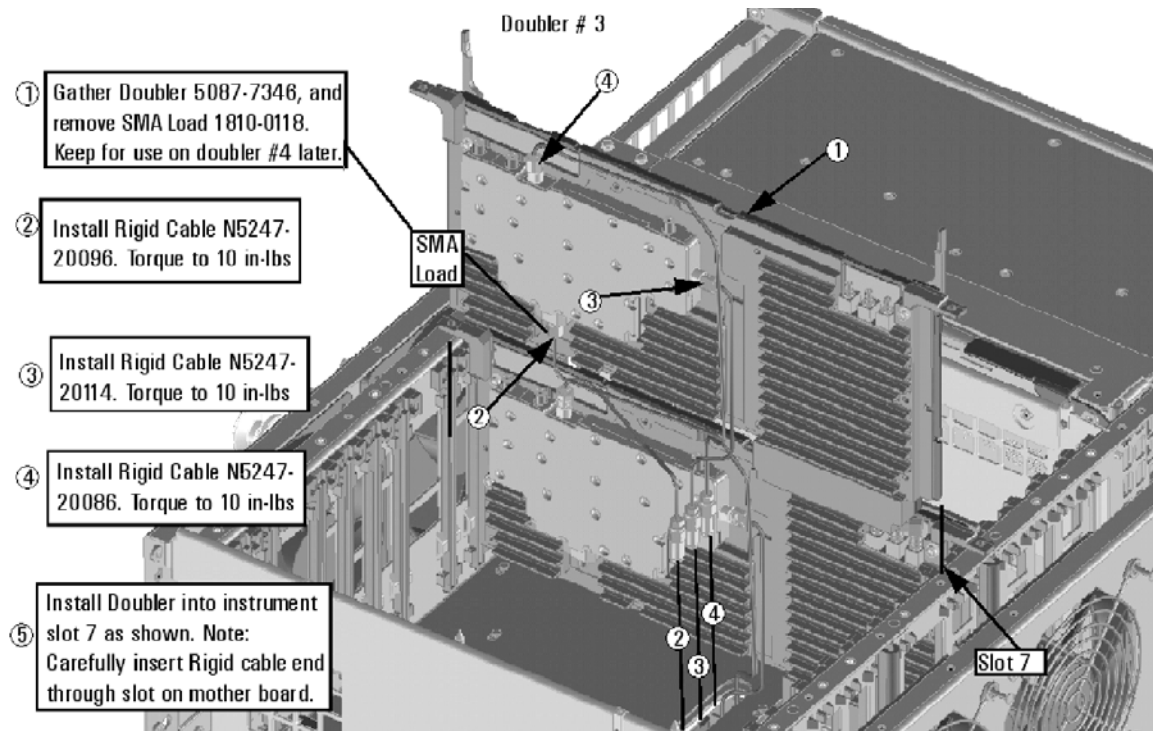

N5247_106_41

Step 21. Install the A12 40 GHz Doubler Cables

Follow the three instructions shown in [Figure 12](#).

Figure 12 A12 40 GHz Doubler 3 Assembly Cable Installation

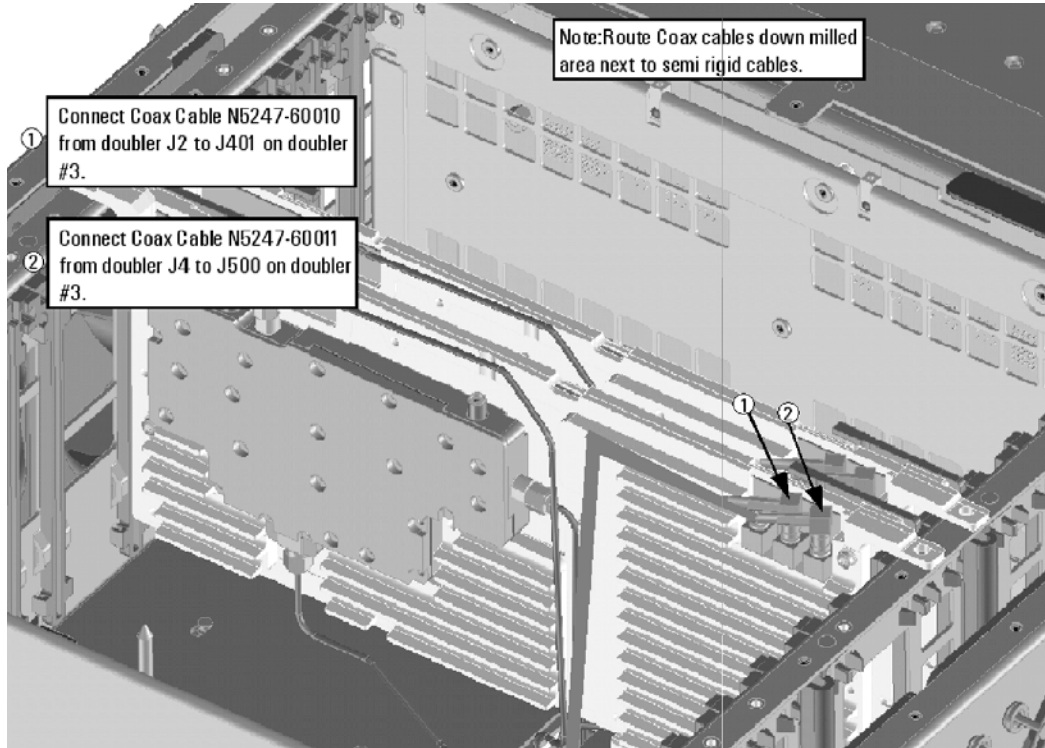

N5247_106_44

Step 22. Install the A10 26.5 GHz Source 2 Assembly and Cables

Follow the four instructions shown in [Figure 13](#).

Figure 13 A10 Source 2 Assembly Installation

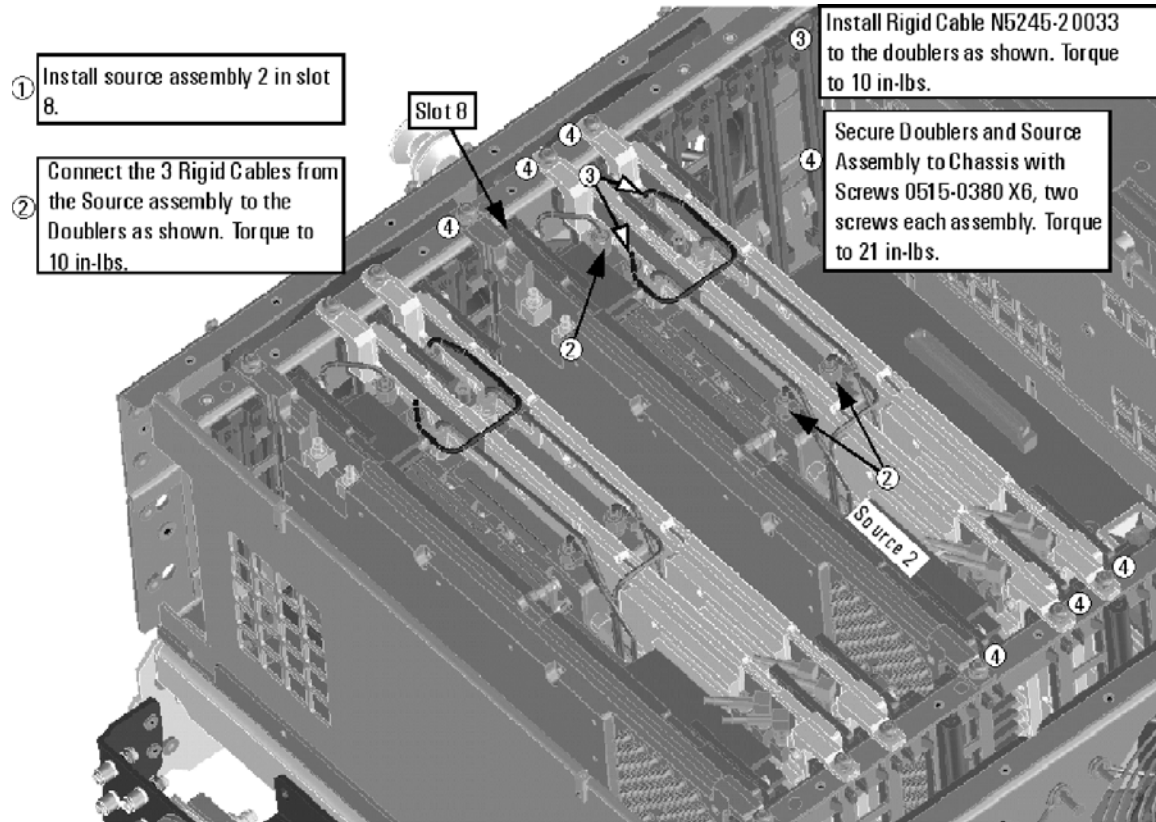

N5247_106_45

Step 23. Install the A17 13.5 GHz (Source 2) Synthesizer Board and Cables

1. Install new gray cable W87 (N5242-60030) to connector J5 of the new A17 (source 2) synthesizer board (N5242-60150). The loose end of the cable will be connected on the A14 frequency reference board (J7) after the A17 board has been installed in the analyzer.
2. Install the A17 board into slot 2 in the motherboard. Secure the board into the chassis using two screws (0515-0380). To see an image showing the location of the A17 board in the motherboard, click the Chapter 6 bookmark "Top Assemblies, All Options" in the PDF Service Guide¹.
3. Connect cable W2 (N5245-20100) between the A10 source 2 board and the A17 (source 2) synthesizer board, positioning the cable in the wire looms. Tighten the cable connectors to 10 in-lbs using a 5/16-in torque wrench.
4. Connect the loose end of new gray flex cable W87 (N5242-60030) on the A14 frequency reference board (J7). (The other end of this cable was previously connected to J5 of the source 2 synthesizer board.)

Step 24. Install the Cable Bracket Mount

1. Follow the two instructions shown in [Figure 14](#). New parts are listed in [Table 1 on page 7](#) of this document.

Figure 14 Cable Bracket Mount Installation

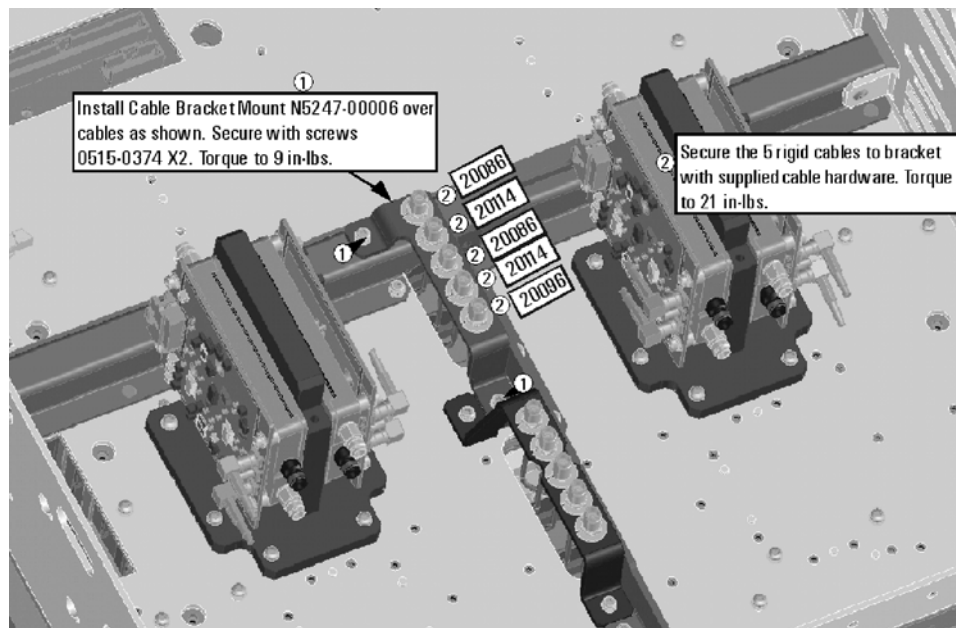

N5247_106_07

Step 25. Remove the A27 Mixer Brick Assembly

Remove the A27 mixer brick assembly from the PNA. For instructions, click the Chapter 7 bookmark, "Removing and Replacing the A27 and A28 Mixer Bricks" in the PDF Service Guide¹.

1. See ["Downloading the Online PNA Service Guide" on page 5](#).

Step 26. Assemble the A28 Mixer Brick Assembly

1. Follow the instruction shown in [Figure 15](#). New parts are listed in [Table 1 on page 7](#) of this document.

Figure 15 **A28 Mixer Brick Assembly**

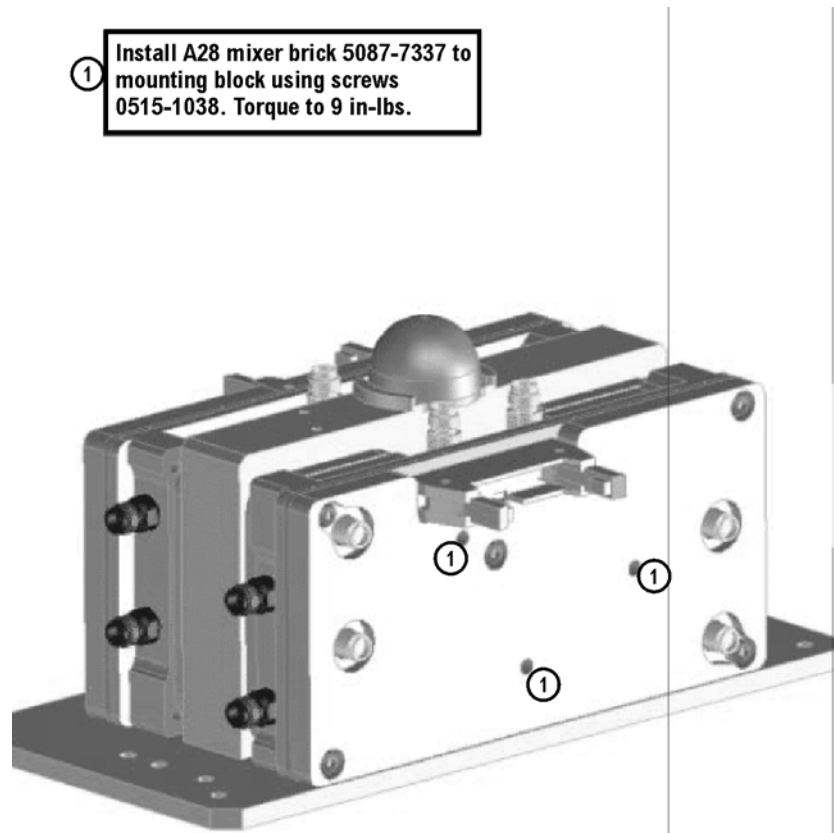

N5247_106_17

2. Follow the instructions shown in [Figure 16](#).

Figure 16 Splitter and 3 dB Pad Installation

① Install splitter 5067-4086 (label facing up), secure with screws 0515-2007 X2. Leave loose for now.

② Install 3dB pad 08490-60037 X1 only on R4 connector of A28 mixer brick. Torque to 10 in-lbs.

③ Add dust cap N5247-20138 X1 (not shown) to L-Brick.

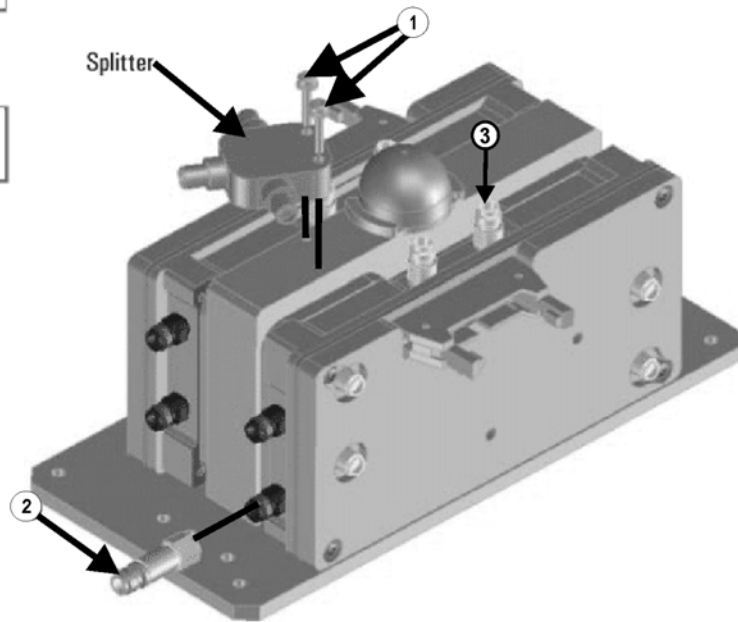

N5247_106_18

3. Connect the gray flexible cables to the A28 mixer in the order shown in [Figure 17](#). The other ends of the cables will be connected when the IF board is reinstalled later.

Figure 17 A28 Mixer Brick Cable Installation

① Install Cable N5242-60024,

② Install Cable N5242-60019,

③ Install Cable N5242-60020,

④ Install Cable N5242-60023,

⑤ Torque SMA nuts to 10 in-lbs.
Note: Orientation of Gray Cable
SMA connector on **mixer brick**.

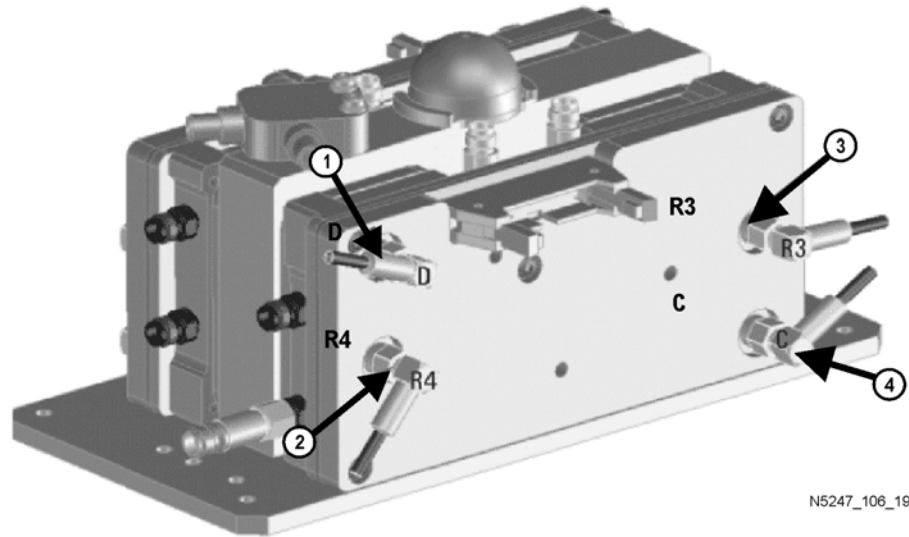

N5247_106_19

Step 27. Install the A27/A28 Mixer Brick Assemblies

Reinstall the A27 mixer brick cables, and then install the A27/A28 mixer brick assembly, reusing the 10 existing screws. For instructions, click the Chapter 7 bookmark, “Removing and Replacing the A27 and A28 Mixer Bricks” in the PDF Service Guide¹. New parts are listed in [Table 1 on page 7](#) of this document.

1. See “[Downloading the Online PNA Service Guide](#)” on page 5.

Step 28. Assemble the Port 3 and Port 4 Attenuator Assemblies

Follow the instruction shown in [Figure 18](#). New parts are listed in [Table 1 on page 7](#) of this document

Figure 18 Port 3 and Port 4 Attenuator Assemblies

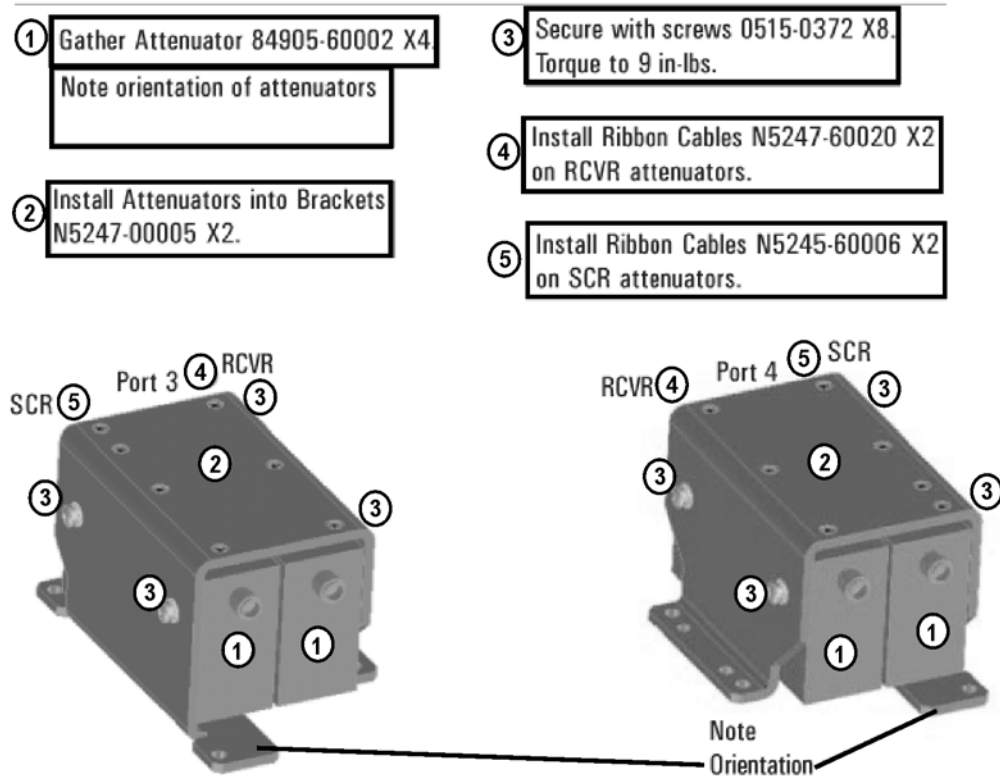

N5247_106_22

Step 29. Install the Port 3 and Port 4 Attenuator Assemblies on the Test Set Deck

Install the Port 3 and Port 4 attenuator assemblies using four 0515-0372 screws to secure each bracket. For instructions, click the Chapter 7 bookmark, "Removing and Replacing the A38-A41 Source Attenuators and the A46-A49 Receiver Attenuators" in the PDF Service Guide¹. New parts are listed in [Table 1 on page 7](#) of this document.

Refer to [Figure 21 on page 35](#) for the location of the attenuator assemblies.

Step 30. Assemble the A30 and A31 receiver coupler Assemblies

Follow the instructions shown in [Figure 19](#) and [Figure 20](#). New parts are listed in [Table 1 on page 7](#) of this document.

Figure 19 A30 receiver coupler Assembly

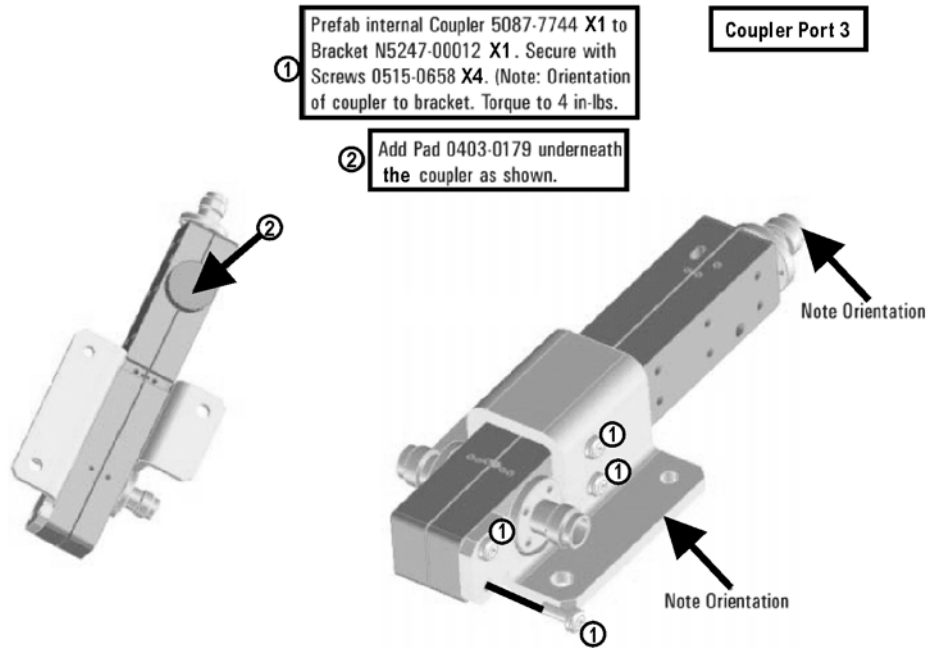

N5247_106_20

Figure 20 A31 receiver coupler Assembly

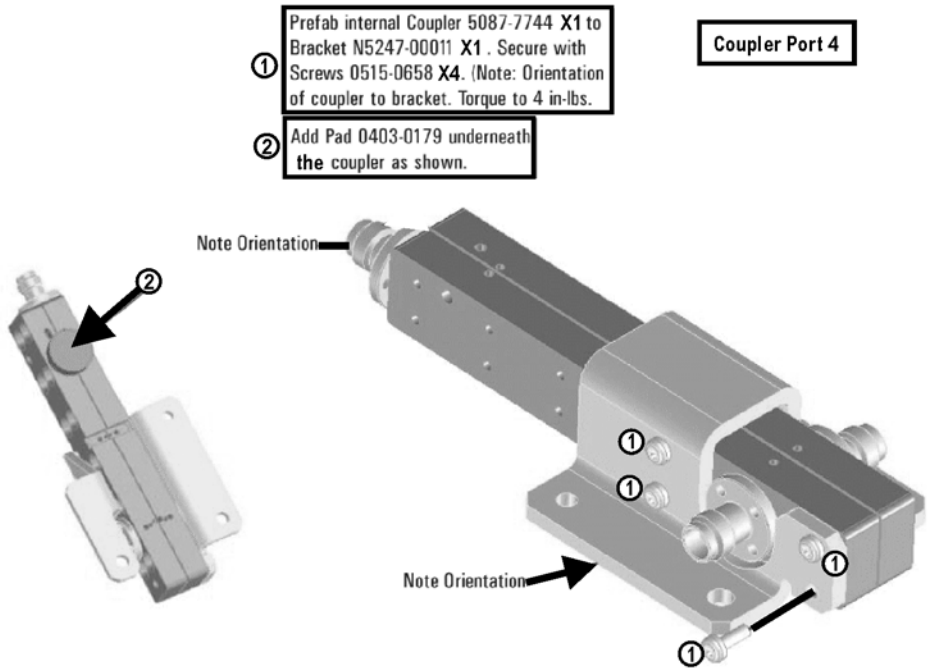

N5247_106_21

Step 31. Install the A30 and A31 receiver coupler Assemblies

Install the A30 and A31 receiver coupler assemblies using three 0515-0372 screws to secure each bracket. For instructions, click the Chapter 7 bookmark, “Removing and Replacing the A29-A32 receiver couplers and receiver coupler Mounting Brackets” in the PDF Service Guide¹. New parts are listed in [Table 1 on page 7](#) of this document.

Refer to [Figure 21](#) below for the location of the receiver coupler assemblies.

Figure 21 Location of Attenuator Assemblies and receiver coupler Assemblies

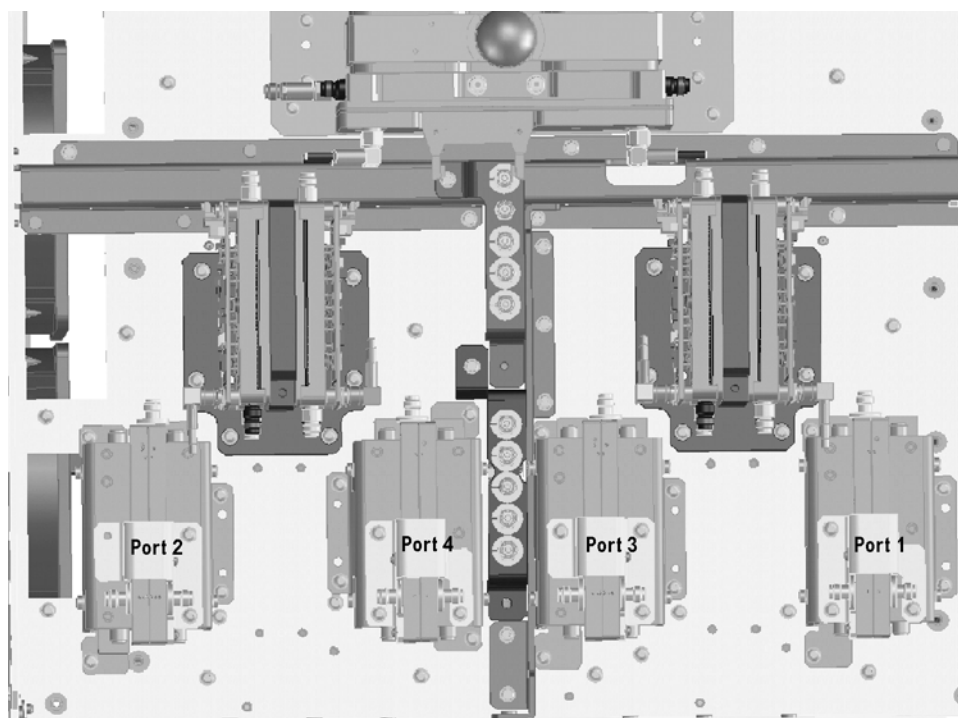

N5247_106_14

Step 32. Remove the Bias Tee Blocks From the Test Set Deck

Remove the two bias tee blocks from the test set deck. For instructions, click the Chapter 7 bookmark, “Removing and Replacing the A42-A45 Bias Tees” in the PDF Service Guide¹. Keep all parts for reinstallation later.

1. See “[Downloading the Online PNA Service Guide](#)” on page 5.

Step 33. Install the A43 and A44 Bias Tees on the Bias Tee Blocks

Follow the instruction in [Figure 22](#) to install the A43 and A44 bias tees on the bias tee blocks. New parts are listed in [Table 1 on page 7](#) of this document.

Figure 22 Installing A43 and A44 Bias Tees on the Bias Tee Blocks

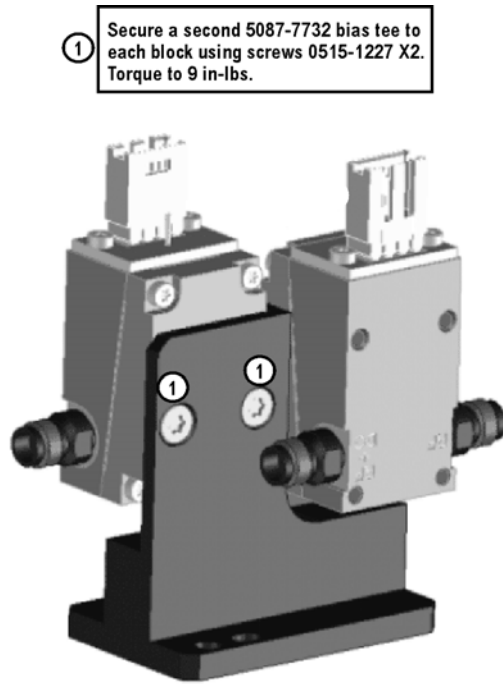

N5247_106_02

Step 34. Reinstall the Bias Tee Blocks

Reinstall the two bias tee blocks on the test set deck, reusing the existing screws. For instructions, click the Chapter 7 bookmark, “Removing and Replacing the A42-A45 Bias Tees” in the PDF Service Guide¹.

NOTE As shown in “Removing and Replacing the A42-A45 Bias Tees” in the PDF Service Guide, the slot on the bias tee block should be oriented toward the back of the PNA.

1. See “[Downloading the Online PNA Service Guide](#)” on page 5.

Step 35. Assemble the A33 - A36 Test Port Coupler Assemblies

1. Remove the A33 test port 1 coupler and A36 test port 2 coupler from the PNA. For instructions, click the Chapter 7 bookmark, "Removing and Replacing the A33 - A36 Test Port Couplers" in the PDF Service Guide¹.
2. Using pliers, remove the adhesive bumper on the A33 test port 1 coupler and on the A36 test port 2 coupler.
3. Follow the two instructions shown in [Figure 23](#). New parts are listed in [Table 1 on page 7](#) of this document.

Figure 23 A33 - A36 Test Port Coupler Assembly

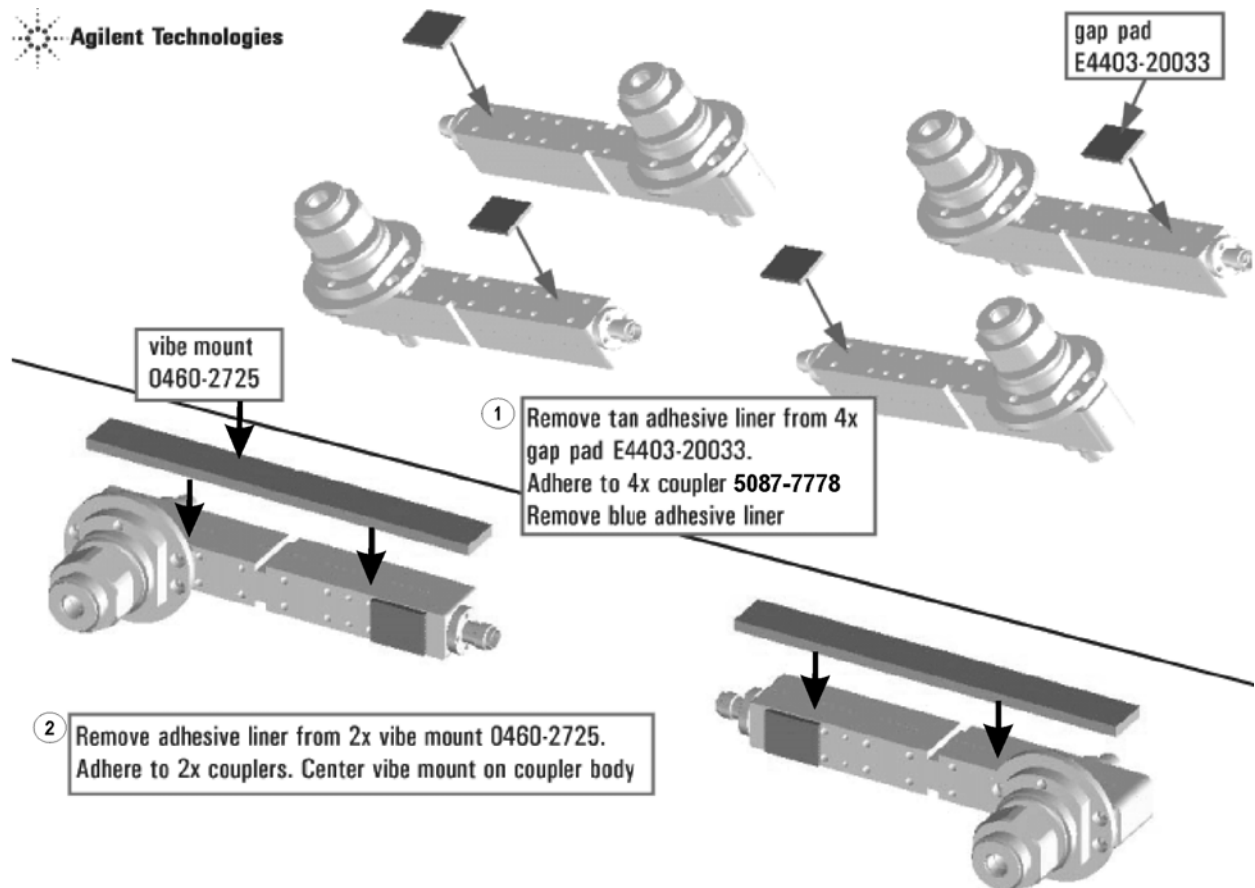

N5247_106_11

Step 36. Remove and Disassemble the 2-Port Test Set Front Plate

1. Remove two screws from each LED board and remove the boards from the 2-port test set front plate of the PNA. Keep the screws for reinstallation later.
2. Remove the 2-port test set front plate from the test set deck. Keep the screws to reuse later.
3. Remove the 12 bulkhead connectors, nuts and washers from the 2-port front plate to reuse later.

Step 37. Install the LED Boards, Bulkhead Connectors, and Test Port Coupler Assemblies to the 4-Port Test Set Front Plate

1. Follow the three instructions shown in [Figure 24](#).

Figure 24 LED Board Assemblies and Test Port Coupler Assemblies Installation

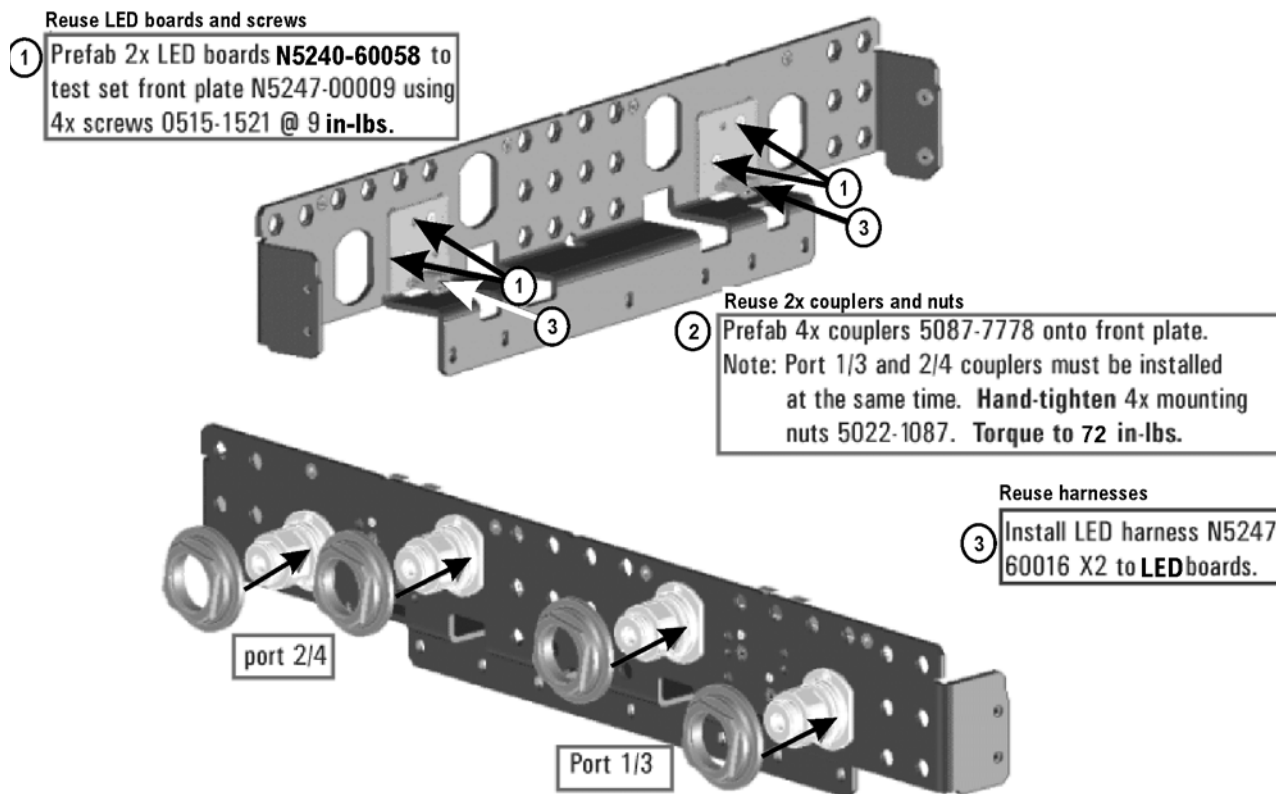

N5247_1

2. Reinstall the 12 bulkhead connectors, nuts and washers taken from the 2-port front plate into the 4-port front plate. Torque to 21 in-lbs.
3. Install 12 new bulkhead connectors (5065-4673), nuts (1250-3516) and washers (1250-3310) into the 4-port front plate. Torque to 21 in-lbs.

Step 38. Install the 4-Port Coupler Plate Assembly to the Deck

Follow the three instructions shown in [Figure 25](#).

Figure 25 Coupler Plate Assembly Installation

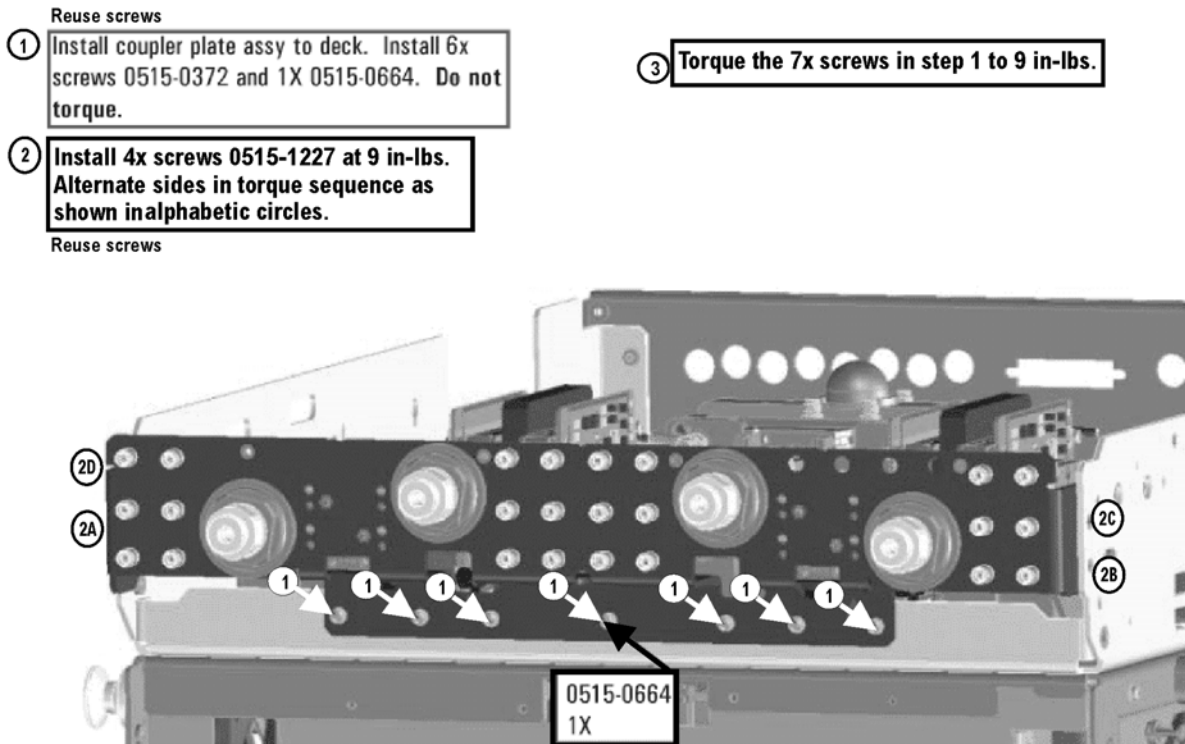

N5247_106_13

Step 39. Install Some Bottom-Side (Test Set) Cables

CAUTION Use a 5/16-in torque wrench set to 10 in-lbs on all cable connections except the front and rear panel bulkhead connectors. On these, use a 9 mm nutsetter or open end torque wrench set to 21 in-lb.

CAUTION Be careful not to damage the center pins of the semirigid cables. Some flexing of the cables may be necessary but do not over-bend them.

CAUTION Follow instructions carefully when making cable connections, especially wire harness connections. Incorrect connections can destroy components, resulting in additional customer costs.

Flexible Cables Required for Upgrading to an Option 419 PNA

Install the following gray flexible cables in the order listed. 70 GHz cables were connected to the 70 GHz doublers earlier in this procedure, but the other end of these cables still requires a connection. To see images showing the location of these cables, click either of the Chapter 6 bookmarks “Bottom RF Cables, 4-Port, Option 419” in the PDF Service Guide¹. New parts are listed in [Table 1 on page 7](#).

- W91 (reuse) (N5247-60006) A60 port 1 70 GHz doubler (J2) to A7 40 GHz doubler (J401)
- W92 (reuse) (N5247-60007) A60 port 1 70 GHz doubler (J4) to A7 40 GHz doubler (J500)
- W97 (reuse) (N5247-60008) A63 port 2 70 GHz doubler (J2) to A8 40 GHz doubler (J401)
- W98 (reuse) (N5247-60009) A63 port 2 70 GHz doubler (J4) to A8 40 GHz doubler (J500)

Semirigid Cables Required for Upgrading to an Option 419 PNA

To see images showing the location of these cables, click the Chapter 6 bookmark “Bottom RF Cables, 4-Port, Option 419” in the PDF Service Guide¹. New parts are listed in [Table 1 on page 7](#).

- W69 (reuse) (N5247-20112) A27 mixer brick to rear-panel EXT TSET DRIVE LO OUT (J5)
- W68 (N5247-20088) rear panel port RF2 OUT (J12) to W67
 - * Install SMA load previously removed from A10 26.5 GHz source board onto rear panel port RF2 OUT (J12).
- W123 (reuse) (N5247-20020) A49 port 2 receiver attenuator to port 2 RCVR B IN
- W115 (reuse) (N5247-20027) A45 port 2 bias tee to port 2 CPLR THRU
- W46 (N5247-20019) A36 port 2 coupler to port 2 CPLR ARM
- W114 (reuse) (N5247-20034) A41 port 2 source attenuator to port 2 SOURCE OUT
- W112 (N5247-20029) A44 port 4 bias tee to A35 port 4 coupler
- W45 (reuse) (N5247-20058) A32 port 2 receiver coupler to REF 2 SOURCE OUT
 - * As shown in [Figure 26](#), install clamps to secure W45.
- W124 (reuse) (N5247-20046) A49 port 2 receiver attenuator to A27 mixer brick (B)
- W145 (N5247-20066) A27 mixer brick (R2) to REF 2 RCVR R2 IN
 - * As shown in [Figure 26](#), install clamp part number 1400-1334 to secure W145.

1. See “[Downloading the Online PNA Service Guide](#)” on page 5.

Figure 26

Location of W45 and W145 Cable Securing Clamps

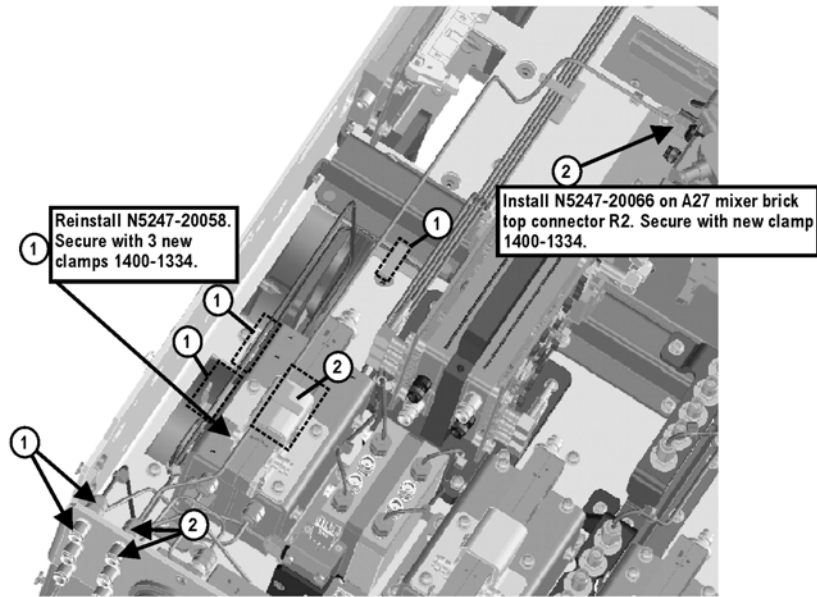

N5247_106_04

- W116 (N5247-20080) A45 port 2 bias tee to A36 port 2 coupler
- W121 (N5247-20024) A48 port 4 receiver attenuator to port 4 RCVR D IN
- W111 (N5247-20021) A44 port 4 bias tee to port 4 CPLR THRU
- W42 (N5247-20026) A35 port 4 coupler to port 4 CPLR ARM
- W110 (N5247-20025) A40 port 4 source attenuator to port 4 SOURCE OUT
- W41 (N5247-20069) A31 port 4 receiver coupler to REF 4 SOURCE OUT
- W55 (N5247-20067) A28 mixer brick (R4) to REF 4 RCVR R4 IN

* As shown in [Figure 27](#), install clamp part number 1400-1334 to secure W41, and install cable tie part number 1400-0249 to secure W55.

Figure 27 Location of Cable Clamp to Secure W41 and Cable Tie to Secure W55

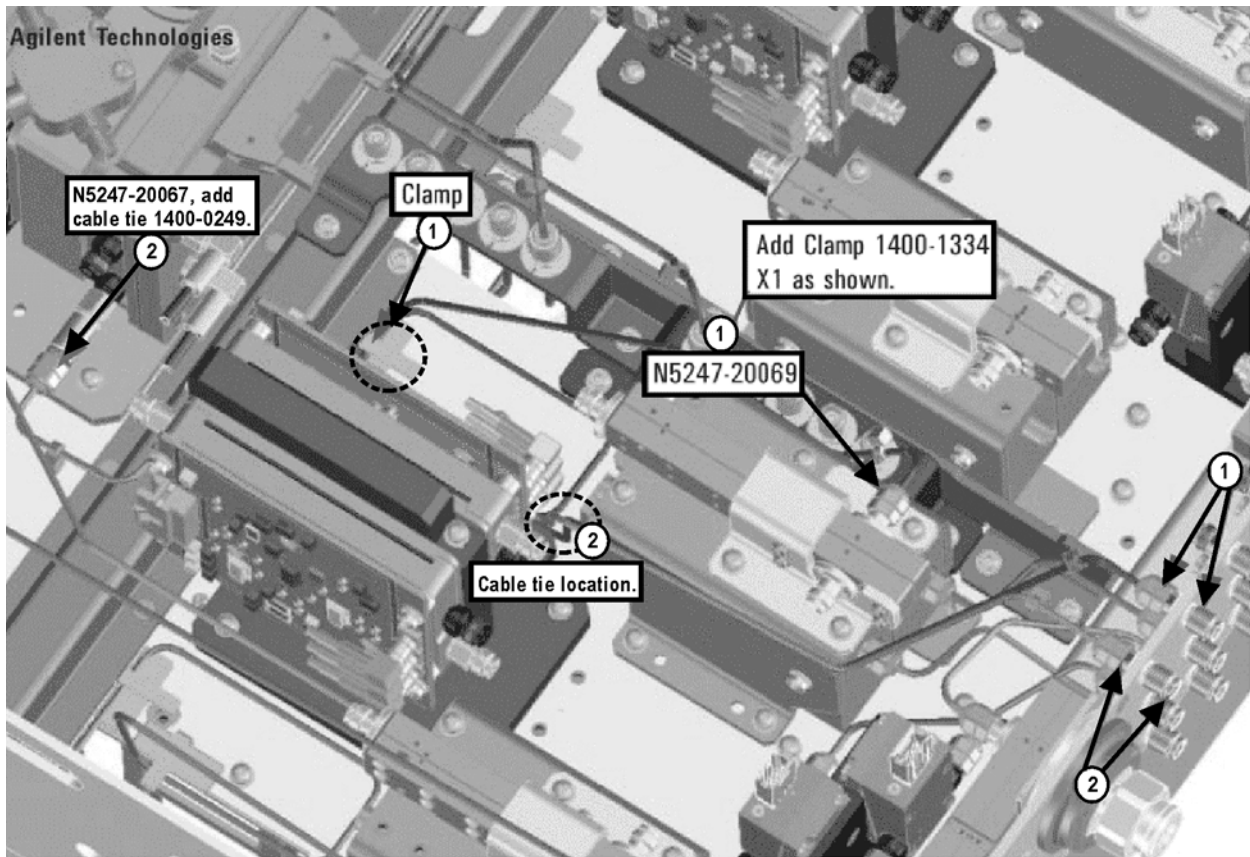

N5247_106_05

- W104 (N5247-20022) A42 port 1 bias tee to A33 port 1 coupler
 - W119 (N5247-20008) Port 3 RCVR C IN to A47 port 3 receiver attenuator
 - W38 (N5247-20007) Port 3 CPLR ARM to A34 port 3 coupler
 - W106 (N5247-20009) Port 3 SOURCE OUT to A39 port 3 source attenuator
 - W103 (N5247-20010) A42 port 1 bias tee to port 1 CPLR THRU
 - W37 (N5247-20070) A30 port 3 receiver coupler to front panel REF 3 SOURCE OUT
- * As shown in [Figure 28](#), install clamp part number 1400-1334 to secure W37.

Figure 28 **Location of Cable Clamp to Secure W37**

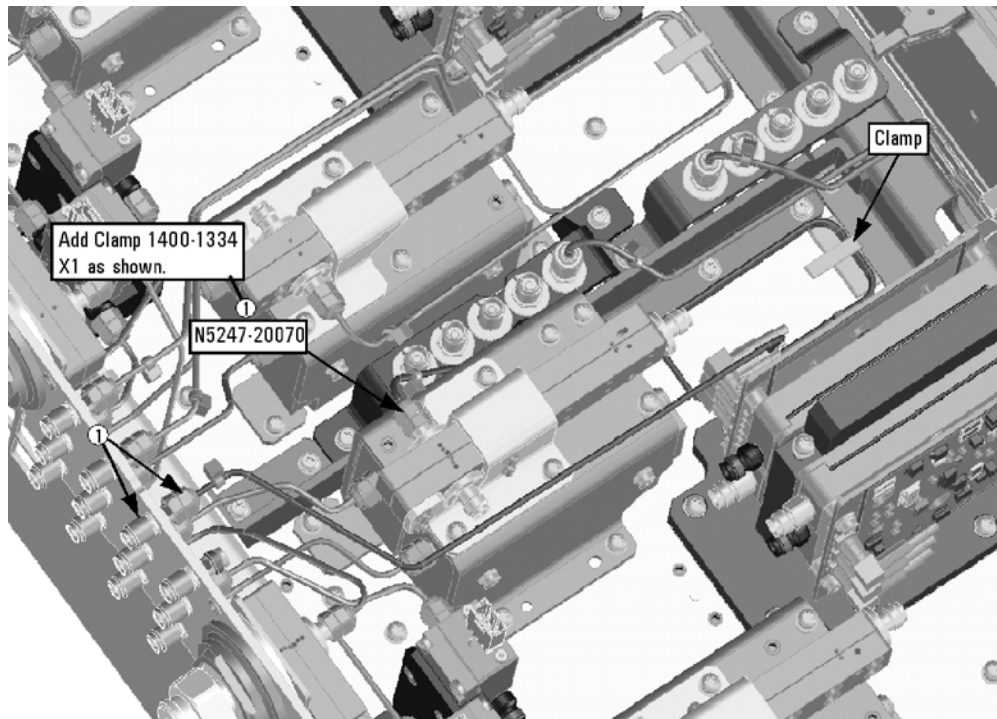

N5227_110_02

- W18 (N5247-20084) A61 port 3 70 GHz doubler to W17
- W14 (reuse) (N5247-20072) A60 port 1 70 GHz doubler to W13
- W120 (N5247-20064) A47 port 3 receiver attenuator to A28 mixer brick (C)
- W54 (N5247-20062) REF 3 RECEIVER R3 IN to A28 mixer brick (R3)

* As shown in [Figure 29](#), install two cable ties, part number 1400-0249, to secure W120 and W54.

Figure 29 Location of Cable Ties to Secure W120/W54

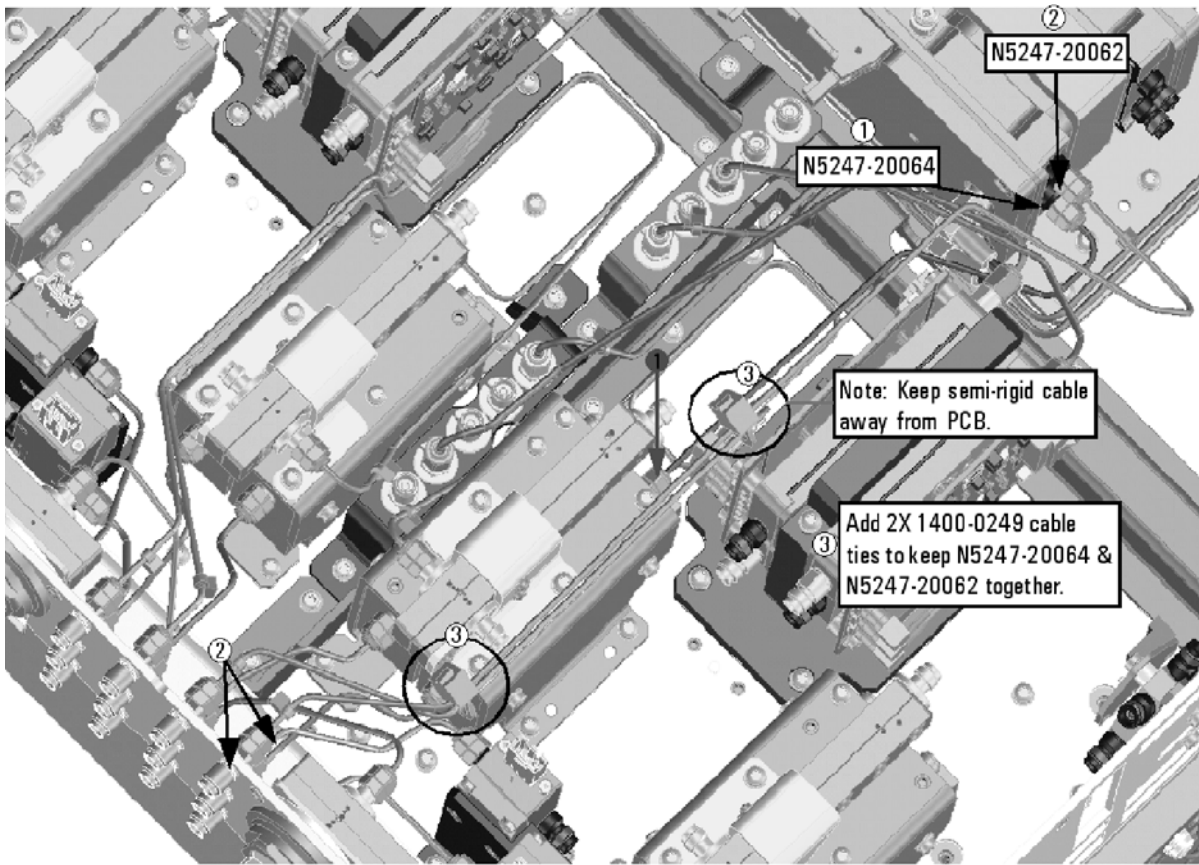

N5227_110_01

- W107 (N5247-20081) A43 port 3 bias tee to port 3 CPLR THRU
- W34 (N5247-20082) A33 port 1 coupler to port 1 CPLR ARM
- W117 (reuse) (N5247-20013) A46 port 1 receiver attenuator to port 1 RCVR A IN
- W102 (reuse) (N5247-20014) A38 port 1 source attenuator to port 1 SOURCE OUT
- W108 (N5247-20028) A43 port 3 bias tee to A34 port 3 coupler
- W144 (N5247-20071) A29 port 1 receiver coupler to A37 reference mixer switch

* As shown in [Figure 30](#), install cable tie, part number 1400-0249, to secure W144.

Figure 30 Location of Cable Tie to Secure W144

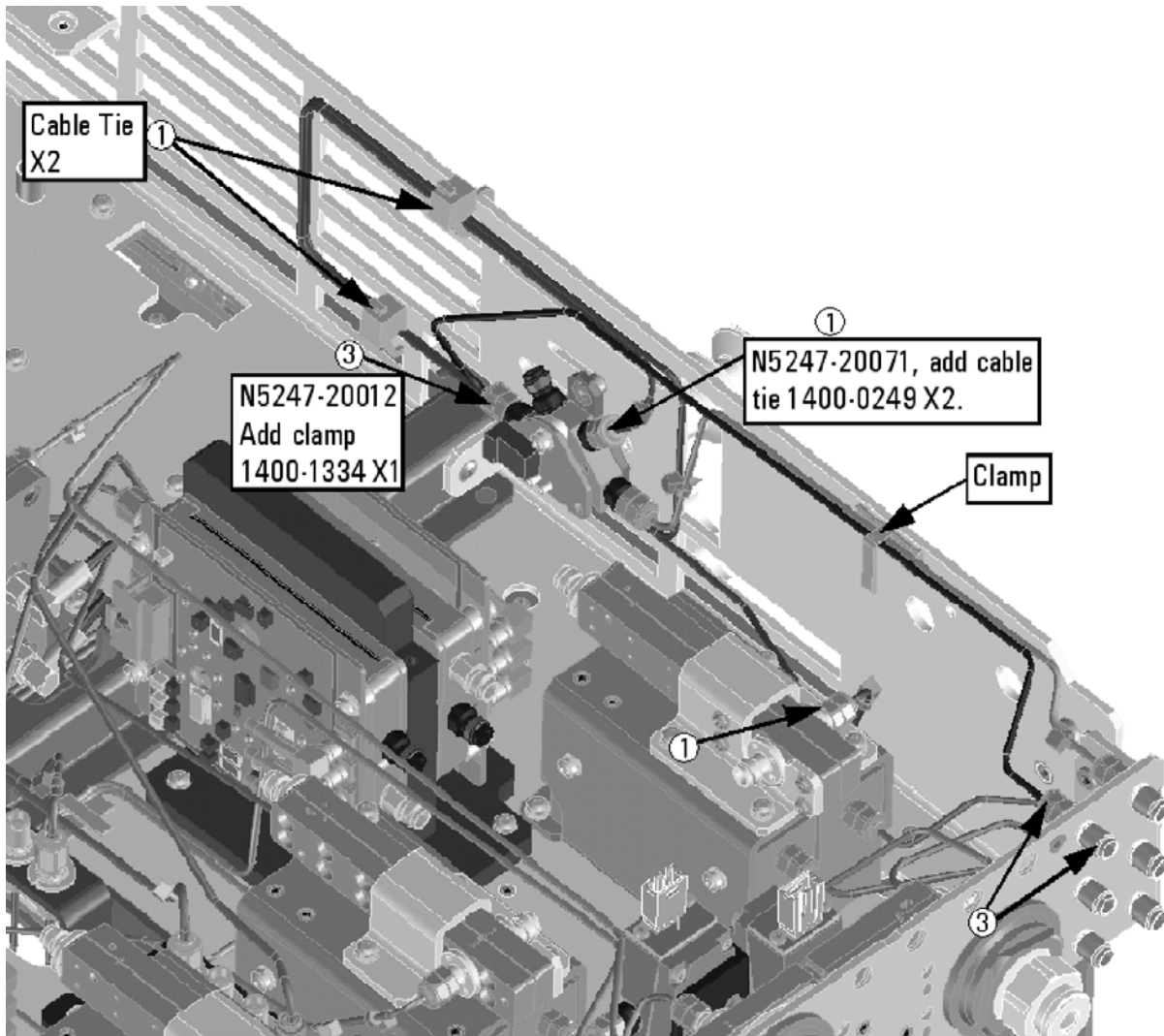

N5247_106_03

- W51 (reuse) (N5247-20011) A37 reference mixer switch to REF 1 SOURCE OUT
- W52 (reuse) (N5247-20012) A37 reference mixer switch to REF 1 RCVR R1 IN
- * As shown in [Figure 30](#), install cable clamp, part number 1400-1334, to secure W52.
- W53 (reuse) (N5247-20048) A37 reference mixer switch to A27 mixer brick (R1)
- W118 (reuse) (N5247-20047) A46 port 1 receiver attenuator to A27 mixer brick (A)
- W122 (N5247-20065) A48 port 4 receiver attenuator to A28 mixer brick (D)
- W101 (reuse) (N5247-20083) A29 port 1 receiver coupler to A38 port 1 source attenuator
- W113 (reuse) (N5247-20083) A32 port 2 receiver coupler to A41 port 2 source attenuator
- W105 (N5247-20083) A30 port 3 ref coupler to A39 port 3 source attenuator
- W109 (N5247-20083) A31 port 4 ref coupler to A40 port 4 source attenuator

- W27 (reuse) (N5247-20044) A60 port 1 70 GHz doubler to A29 port 1 receiver coupler
- W28 (N5247-20043) A61 port 3 70 GHz doubler to A30 port 3 receiver coupler
- W16 (N5247-20060) A61 port 3 70 GHz doubler to W15
- W12 (reuse) (N5247-20059) A60 port 1 70 GHz doubler to W11
- W29 (N5247-20044) A62 port 4 70 GHz doubler to A31 port 4 receiver coupler
- W20 (N5247-20015) A62 port 4 70 GHz doubler to W19
- W24 (reuse) (N5247-20061) A63 port 2 70 GHz doubler to W23
- W30 (reuse) (N5247-20043) A63 port 2 70 GHz doubler to A32 port 2 receiver coupler
- W22 (N5247-20068) A62 port 4 70 GHz doubler to W21
- W26 (reuse) (N5247-20051) A63 port 2 70 GHz doubler to W25
- W64 (N5245-20022) A26 splitter to A28 mixer brick
- W63 (N5245-20023) A26 splitter to A27 mixer brick
- W62 (N5247-20111) A26 splitter to A25 HMA26.5

* Tighten the screws that secure the A26 splitter to the mixer mounting block.

Step 40. Install Cables on IF Multiplexer Board

Install the following gray flexible cables in the order listed. Mixer brick cables were connected to the mixer bricks earlier in this procedure, but the other ends of these cables still require a connection. To see images showing the location of these cables, click either of the Chapter 6 bookmarks “Bottom RF Cables, 4-Port, Option 419” in the PDF Service Guide¹. New parts are listed in [Table 1 on page 7](#).

- W80 (N5242-60013) A24 IF multiplexer board P203 to A16 SPAM board J2
- W82 (N5242-60015) A24 IF multiplexer board P603 to A16 SPAM board J5
- W71 (reuse) (N5242-60017) A27 mixer brick (A) to A24 IF multiplexer (P1)
- W72 (N5242-60021) A27 mixer brick (R1) to A24 IF multiplexer (P411)
- W73 (N5242-60022) A27 mixer brick (R2) to A24 IF multiplexer (P412)
- W74 (reuse) (N5242-60018) A27 mixer brick (B) to A24 IF multiplexer (P201)
- W75 (N5242-60024) A28 mixer brick (D) to A24 IF multiplexer (P801)
- W76 (N5242-60019) A28 mixer brick (R4) to A24 IF multiplexer (P414)
- W77 (N5242-60020) A28 mixer brick (R3) to A24 IF multiplexer (P413)
- W78 (N5242-60023) A28 mixer brick (C) to A24 IF multiplexer (P601)
- W79 (reuse) (N5242-60012) A24 IF multiplexer board P3 to A16 SPAM board J1
- W81 (reuse) (N5242-60014) A24 IF multiplexer board P403 to A16 SPAM board J4
- W83 (reuse) (N5242-60016) A24 IF multiplexer board P803 to A16 SPAM board J6

Step 41. Reinstall the Testset Stabilizer Bracket on the A24 IF Multiplexer Board

Reinstall the stabilizer bracket - see [Figure 2](#).

Step 42. Reinstall the A23 Test Set Motherboard

1. For instructions on reinstalling the board, click the Chapter 7 bookmark “Removing and Replacing the A23 test set motherboard” in the PDF Service Guide¹.

Step 43. Install Cables on the A23 Test Set Motherboard

CAUTION Follow instructions carefully when making cable connections, especially wire harness connections. Incorrect connections can destroy components, resulting in additional customer costs.

If not already done in a previous step, install the following new ribbon cables and wire harness in the order listed. To see an image showing their locations, click the Chapter 6 bookmark “Bottom Ribbon Cables and Wire Harnesses, 4-Port, Option 419” in the PDF Service Guide¹. New parts are listed in [Table 1 on page 7](#).

- Ribbon cable (N5247-60015) from A28 mixer brick (2) J52 to A23 test set motherboard J552
- Ribbon cable (N5247-60018), A61 port 3 70 GHz doubler J1 to A23 test set motherboard J5
- Ribbon cable (N5247-60018), A62 port 4 70 GHz doubler J1 to A23 test set motherboard J3
- Ribbon cable (N5247-60021), A43 port 3 bias tee to A23 test set motherboard J543
- Ribbon cable (N5247-60021), A44 port 4 bias tee to A23 test set motherboard J544
- Ribbon cable (N5247-60020), A47 port 3 receiver attenuator to A23 test set motherboard J206
- Ribbon cable (N5247-60020), A48 port 4 receiver attenuator to A23 test set motherboard J207
- Ribbon cable (N5245-60006), A39 port 3 source attenuator to A23 test set motherboard J547
- Ribbon cable (N5245-60006), A40 port 4 source attenuator to A23 test set motherboard J548

1. See “[Downloading the Online PNA Service Guide](#)” on page 5.

Step 44. Install the Braces on the Bottom Side of the PNA

Follow the three instructions shown in [Figure 31](#).

Figure 31 Location of Braces on the Bottom Side of the PNA

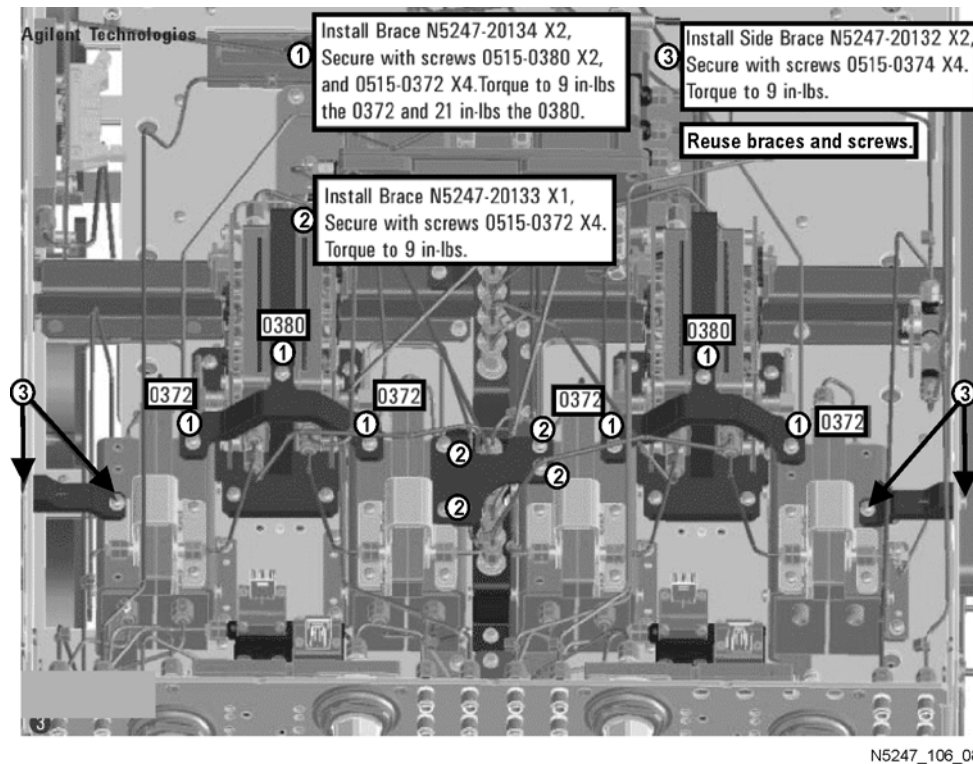

Step 45. Replace the Front Frame in the Front Panel Assembly

Before the front frame can be replaced, the items making up the back side of the front panel assembly must be removed. For instructions on removing these items, click the Chapter 7 bookmark “Removing and Replacing the A1-A3 and Other Front Panel Subassemblies” in the PDF Service Guide¹. New parts are listed in [Table 1 on page 7](#).

1. In the section “Removing the A2 USB Board,” perform the only step.
2. In the section “Removing the A1 Front Panel Interface Board and Keypad Assembly,” perform steps 1 - 5.
3. In the section “Removing the Power Switch Board and Power Button Keypad,” perform only step 1.
4. Remove the braided gasket from the backside edges of the 2-port front frame and install it in the 4-port front frame.
5. Reassemble the front panel assembly with the new 4-port front frame (N5247-20141) by reversing the order of the instructions previously followed.

Step 46. Reinstall Front Panel Assembly

For instructions on reinstalling the front panel assembly, click the Chapter 7 bookmark “Removing and Replacing the Front Panel Assembly” in the PDF Service Guide¹.

Step 47. Install the Overlays and Nameplate

To see an image of the front panel overlay (N5227-80005), keypad overlay (N5242-80005), power button overlay (N5242-80007), and nameplate (N5247-80006), click the Chapter 6 bookmark “Front Panel Assembly, Front Side, All Options” in the PDF Service Guide¹. New parts are listed in [Table 1 on page 7](#).

1. Remove the protective backing from the new front panel overlay (N5227-80005).
2. Loosely place the overlay in the recess on the lower front panel.
3. Placing two fingers at the middle, press the overlay firmly onto the frame while sliding your fingers in opposite directions towards the ends of the overlay. Repeat on all areas of the overlay.
4. Repeat steps 1-3 to install the keypad overlay (N5242-80005).
5. Repeat steps 1-3 to install the power button overlay (N5242-80007).
6. Install the new nameplate (N5247-80006).

Step 48. Install the Jumper Cables

Install twelve W60 front panel jumper cables (N5247-20107) - use 6 new jumpers and reuse 6 old jumpers. To see an image of the front panel jumper cables, click the Chapter 7 bookmark “Removing and Replacing the Front Panel Assembly” in the PDF Service Guide¹.

Step 49. Reinstall the Inner Cover

For instructions, click the Chapter 7 bookmark “Removing the Covers” in the PDF Service Guide¹.

Step 50. Reinstall the Outer Cover

For instructions, click the Chapter 7 bookmark “Removing the Covers” in the PDF Service Guide¹.

Step 51. Enable Options P04 (400) and 419

Procedure Requirements

- The analyzer must be powered up and operating to perform this procedure.
- The network analyzer program must be running.
- A keyboard and mouse must be connected to the network analyzer.

Option Enable Procedure

1. To start the option enable utility, press UTILITY **System**, then **Service**, then **Option Enable**. An option enable dialog box will appear.

2. Click the arrow in the **Select Desired Option** box. A list of available options will appear.
3. In the **Select Desired Option** list, click **P04 - 4-Ports**.
4. Using the keyboard, enter the license key in the box provided. The license key is printed on the the license message you received from Agilent. Enter this key *exactly* as it is printed on the message.
5. Click **Enable**.
6. Click **Yes** in answer to the displayed question in the **Restart Analyzer?** box.
7. Repeat steps 3-6 to enable Option 419, clicking **419 - Src/Rcvr Atten & Bias Ts 4-Port** in step 3.
8. Repeat steps 3-6 to enable Option 419, clicking **419 - Src/Rcvr Atten & Bias Ts 4-Port** in step 3.
9. When the installation is complete, click **Exit**.

Option Verification Procedure

Once the analyzer has restarted and the Network Analyzer program is again running:

1. On the analyzer's **Help** menu, click **About Network Analyzer**.
2. Verify that "P04," and "419" are listed after "Options:" in the display. Click **OK**.

NOTE If the options have not been enabled, perform the ["Option Enable Procedure"](#) again. If the options are still not enabled, contact Agilent Technologies. Refer to ["Getting Assistance from Agilent" on page 3](#).

Step 52. Perform Post-Upgrade Adjustments and Calibration

Adjustments

The following adjustments must be made due to the hardware changes of the analyzer.

- default EE
- source adjustment
- receiver adjustment
- receiver characterization

These adjustments are described in the PNA Service Guide and in the PNA on-line HELP. A list of equipment required to perform these adjustments is also found in the service guide.

After the specified adjustments have been performed, the analyzer should operate and phase lock over its entire frequency range.

Operator's Check

Perform the Operator's Check to check the basic functionality of the analyzer. For instructions, click the Chapter 3 bookmark "Tests and Adjustments" in the PDF Service Guide¹.

If you experience difficulty with the basic functioning of the analyzer, contact Agilent. Refer to ["Contacting Agilent" on page 3](#).

Calibration

Although the analyzer functions, its performance relative to its specifications has not been verified. It is recommended that a full instrument calibration be performed using the analyzer's internal performance test software. To view information on the performance test software, click the Chapter 3 bookmark "Tests and Adjustments" in the PDF Service Guide¹.

Step 53. Prepare the PNA for the User

1. If necessary, reinstall front jumper cables.
2. Install the cable guards, pushing them over the front jumper cables until the cushioning material touches the front panel of the PNA.
3. Install the dust caps on the test ports.
4. Clean the analyzer, as needed, using a damp cloth.

1. See ["Downloading the Online PNA Service Guide"](#) on page 5.

